

P-JAL-B-049-1

-

B-1816

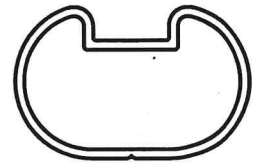

SCALE 1:1

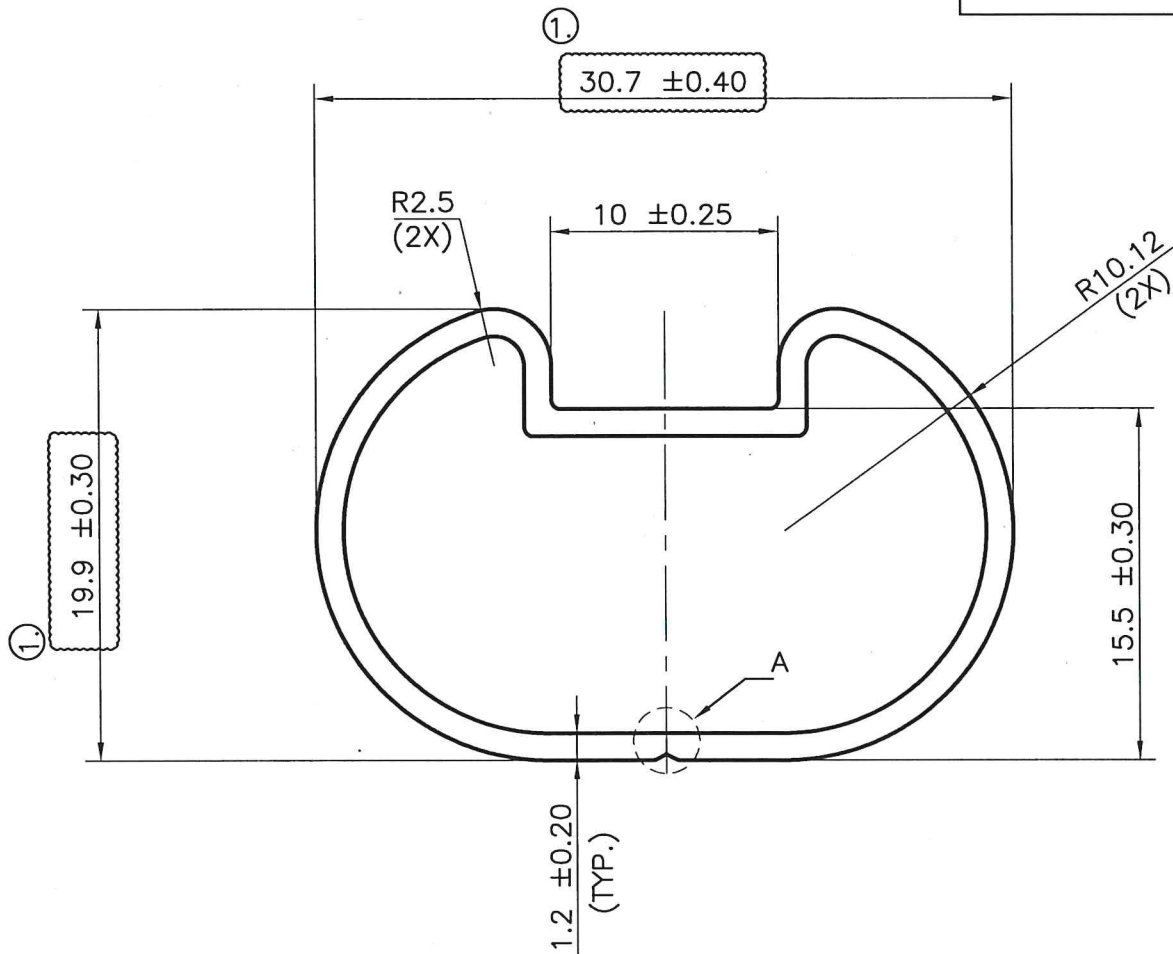

NOTE:-  
 ① Dim. has been revised as per  
 Mail dated 06.12.2022.

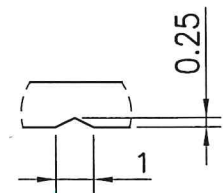

DETAIL A  
 SCALE 5:1



**JINDAL ALUMINIUM LTD.**  
 BHIWADI-301019 (INDIA)

	NAME	DATE
DRAWN	ASHUTOSH	15-09-2022
CHECKED	<i>Juniel</i>	22-12-22
APPROVED	<i>Pran</i>	24/12/22
SCALE		1:1&3:1
AREA	mm <sup>2</sup>	105.28
PERIMETER	mm.	90.87
WEIGHT	kg/m	0.284
DRAWING No.	SECTION No.	
P-JAL-B-049-1	B-1816	
B-1816		

- ALL DIMENSIONS ARE IN mm.
- ROUND OFF ALL SHARP CORNERS WITH 0.40 mm.
- TOLERANCES WILL BE AS PER BS:EN-755-9, UNLESS OTHERWISE SPECIFIED

PARTY'S NAME	M/S. FALCON GARDEN TOOLS PVT. LTD.
PARTY'S DRAWING No.	AS PER DRAWING (FGT/S-64/006/BP)
ALLOY & TEMPER	6063-T6
DESCRIPTION	--