

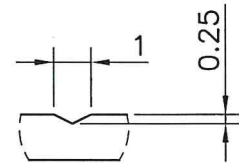

P-JAL-B-050-1
 -
 B-1817

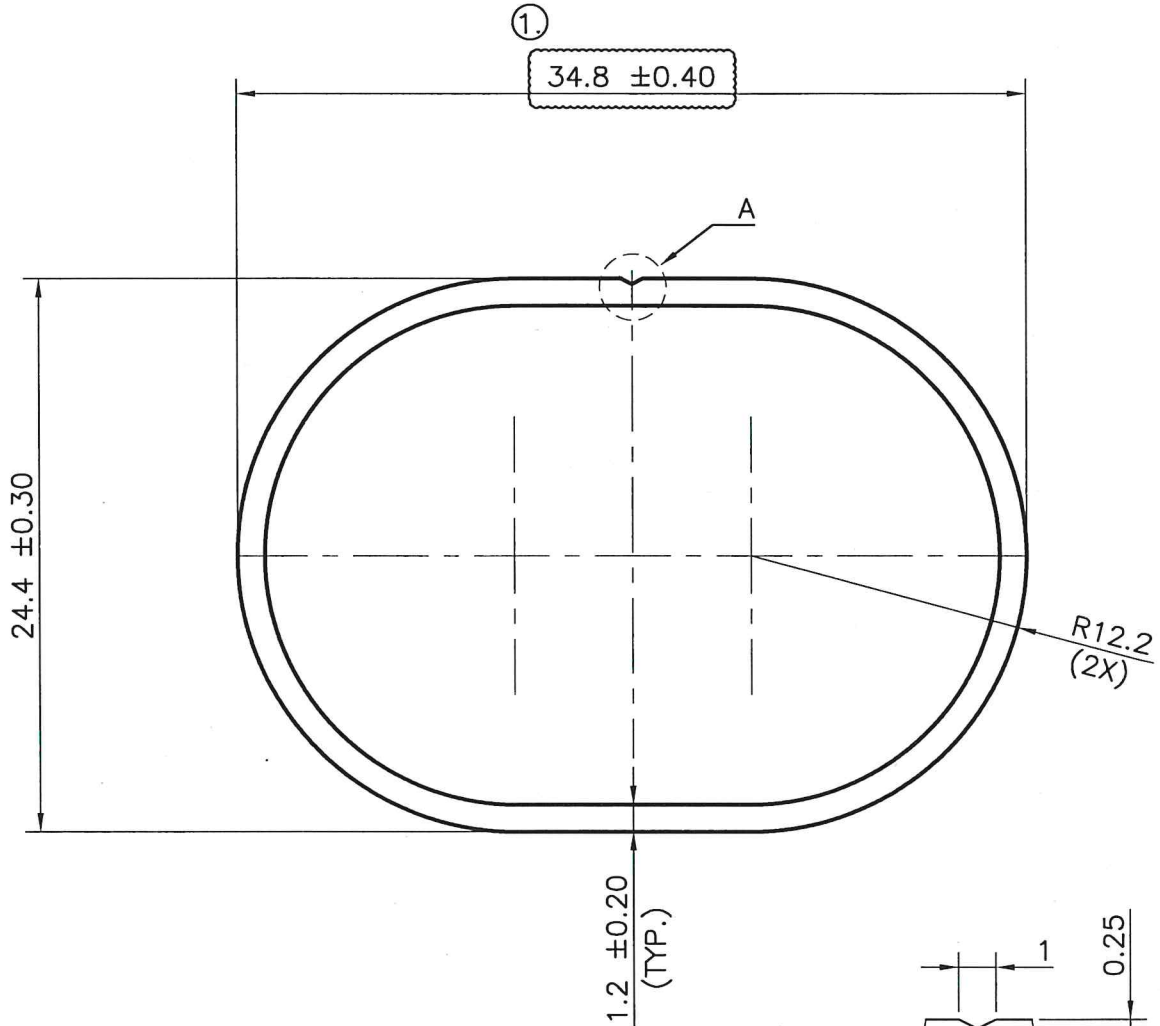
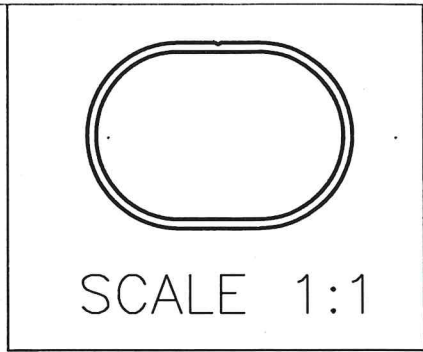

NOTE:-
 ① Tolerance has been revised as per Mail dated 06.12.2022

DETAIL A
 SCALE 5:1

| | | | |
|---|--|----------------------|-------------|
|  SYMBOL OF QUALITY AN ISO 9001 COMPANY | JINDAL ALUMINIUM LTD. BHIWADI-301019 (INDIA) | NAME | DATE |
| | | DRAWN ASHUTOSH | 07-12-2022 |
| 1. ALL DIMENSIONS ARE IN mm. 2. ROUND OFF ALL SHARP CORNERS WITH 0.40 mm. 3. TOLERANCES WILL BE AS PER BS:EN-755-9 , UNLESS OTHERWISE SPECIFIED | | CHECKED <i>Junil</i> | 22-12-22 |
| | | APPROVED <i>Jhan</i> | 22/12/22 |
| PARTY'S NAME M/S. FALCON GARDEN TOOLS PVT. LTD. | | SCALE | 1:1&3:1 |
| | | AREA mm ² | 112.30 |
| PARTY'S DRAWING No. AS PER DRAWING (FGT/S-64/007/BP) | | PERIMETER mm. | 97.57 |
| | | WEIGHT kg/m | 0.303 |
| ALLOY & TEMPER 6063-T6 | | DRAWING No. | SECTION No. |
| | | P-JAL-B-050-1 | B-1817 |
| DESCRIPTION -- | | B-1817 | |
| | | | |