

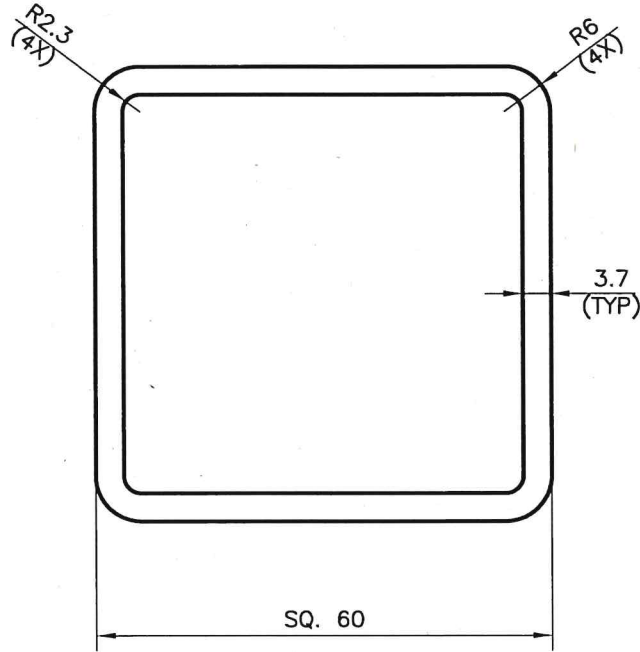

P-JAL-B-068

BEFORE APPROVAL CHECK ALL DIMENSIONS PROPERLY

B-1818



GENERAL WALL THICKNESS :- 3.7 mm

 SYMBOL OF QUALITY AN ISO 9001 COMPANY	JINDAL ALUMINIUM LTD. BHIWADI-301019 (INDIA)		NAME	DATE
		DRAWN	ASHUTOSH	05-12-2022
1. ALL DIMENSIONS ARE IN mm. 2. ROUND OFF ALL SHARP CORNERS WITH 0.40 mm. 3. TOLERANCES WILL BE AS PER BS:EN-755-9 , UNLESS OTHERWISE SPECIFIED		CHECKED	<i>Amil</i>	11-1-23
		APPROVED	<i>Amil</i>	11-01-23
PARTY'S NAME GENERAL SECTION, DELHI		SCALE	1:1	
		AREA mm ²	807	
PARTY'S DRAWING No. AS PER DRAWING (14498)		PERIMETER mm.	229.7	
		WEIGHT kg/m	2.180	
ALLOY & TEMPER 6063-T6		DRAWING No.	SECTION No.	
		P-JAL-B-068	B-1818	
DESCRIPTION SQ. TUBE				