

MAL NO-5097

B276

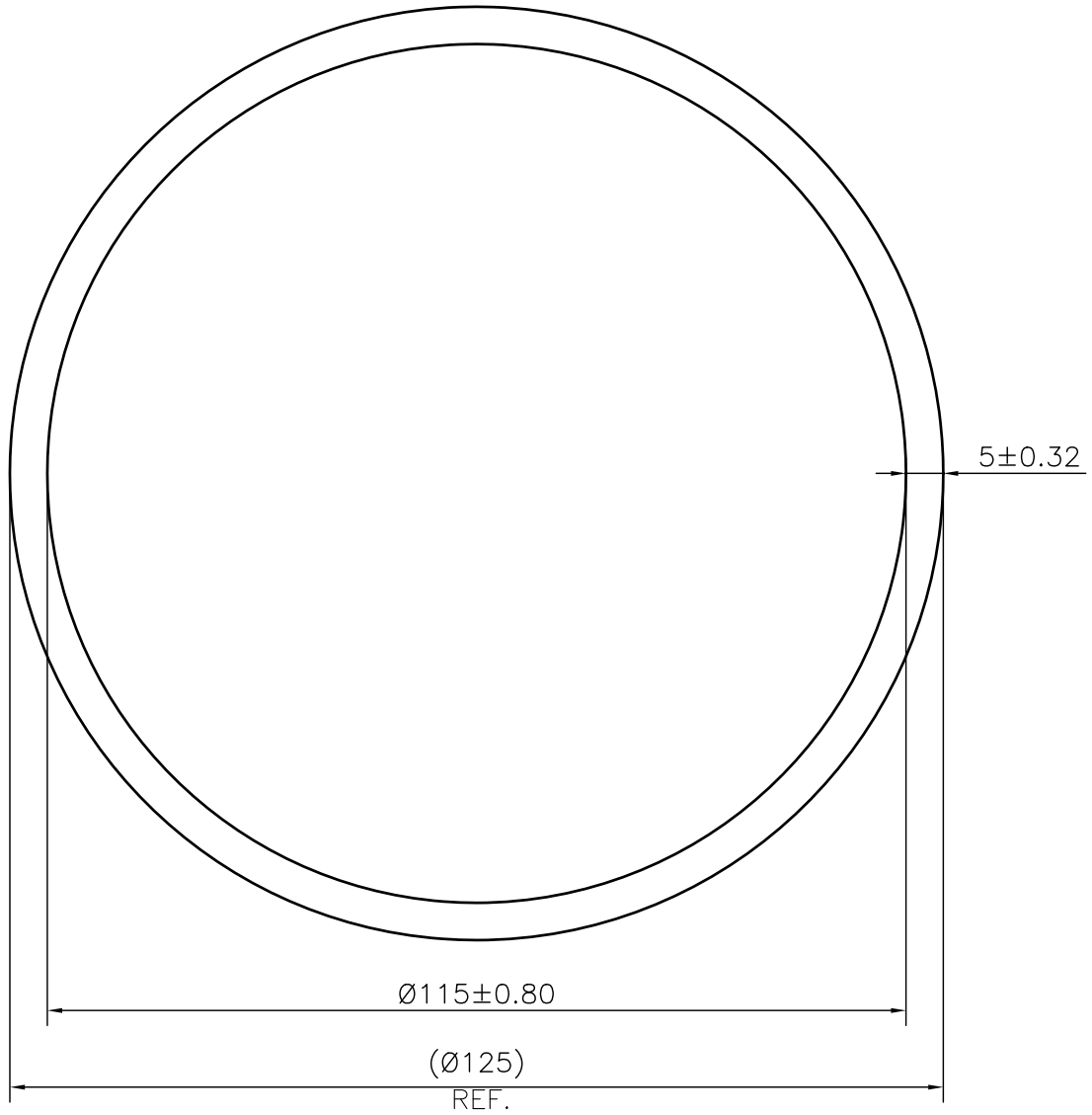

- 1. STRAIGHTNESS= 1.7mm/M
- 2. TWIST= 1.7mm/M
- 3. ANGULARITY= $\pm 2^\circ$
- 4. FLATNESS= 0.007xWIDTH



SYMBOL OF QUALITY
AN ISO 9001 COMPANY

JINDAL ALUMINIUM LTD.
BHIWADI-301019 (INDIA)

	NAME	DATE
DRAWN	ASHUTOSH	18-10-2023
CHECKED		
APPROVED		
SCALE		1:1
AREA mm ²		1884.956
PERIMETER mm.		392.699
WEIGHT kg/m		5.089
DRAWING No.		SECTION No.
MAL NO-5097		-
B276		B276

- 1. ALL DIMENSIONS ARE IN mm.
- 2. ROUND OFF ALL SHARP CORNERS WITH 0.40 mm.
- 3. TOLERANCES WILL BE AS PER BS:EN-755-8 , UNLESS OTHERWISE SPECIFIED

PARTY'S NAME	NATIONAL ALUMINIUM CO.	
PARTY'S DRAWING No.	AS PER DRAWING	
ALLOY & TEMPER	HE30	PRODUCT CODE:-006
		HSN CODE:- 76082000
DESCRIPTION	ROUND TUBE SECTION	