

MAL NO.-12379

B908

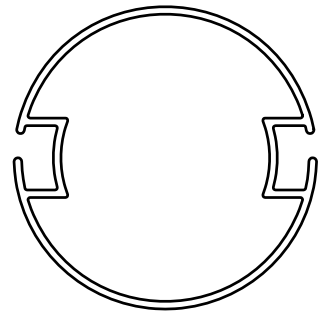

SCALE 1:1

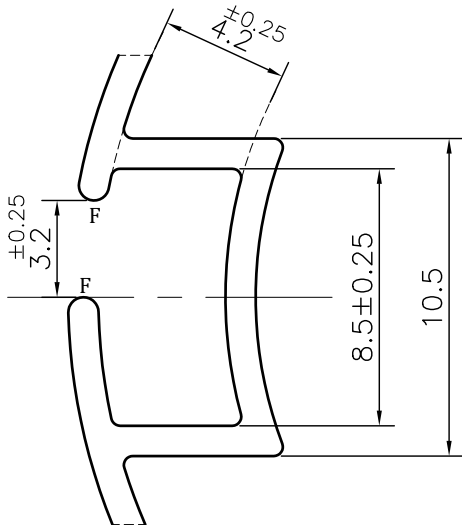
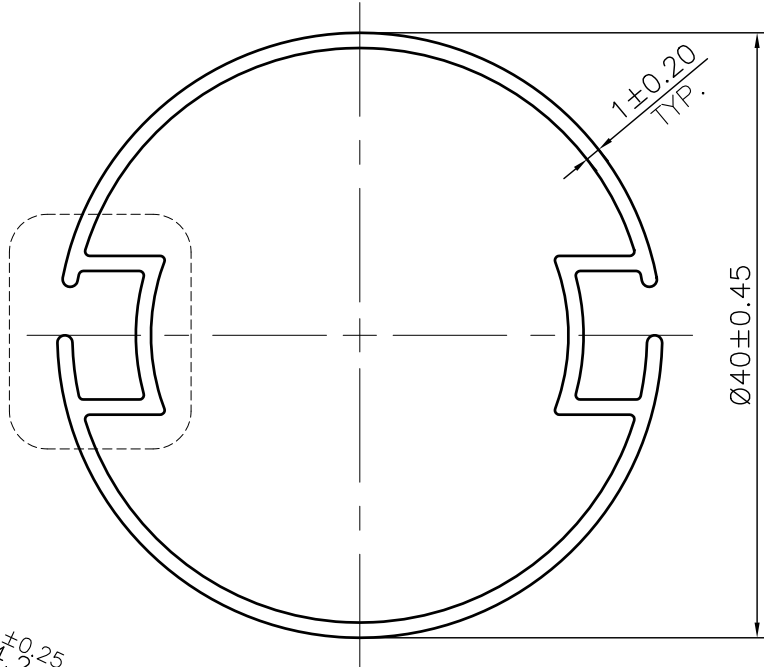

DETAIL A
SCALE 4:1

NOTE:-

F= FULL RADIUS (4 PLACES)

1. STRAIGHTNESS= 1.7mm/M
2. TWIST= 1.7mm/M
3. ANGULARITY= ±2°
4. FLATNESS= 0.007xWIDTH

☞ ROUND OFF ALL SHARP CORNERS WITH 0.30 mm.



SYMBOL OF QUALITY
AN ISO 9001 COMPANY

JINDAL ALUMINIUM LTD.
BHIWADI-301019 (INDIA)

	NAME	DATE
DRAWN	ASHUTOSH	30-08-2023
CHECKED		
APPROVED		
SCALE		2:1
AREA	mm ²	154.835
PERIMETER	mm.	165.548
WEIGHT	kg/m	0.418
DRAWING No.	SECTION No.	
MAL NO.-12379	-	
B908	B908	

1. ALL DIMENSIONS ARE IN mm.
2. ROUND OFF ALL SHARP CORNERS WITH 0.40 mm.
3. TOLERANCES WILL BE AS PER BS:EN-755-9 , UNLESS OTHERWISE SPECIFIED

PARTY'S NAME	JOHNSON	
PARTY'S DRAWING No.	AS PER DRAWING	
ALLOY & TEMPER	6063 T6	PRODUCT CODE:-049
		HSN CODE:- 76042100
DESCRIPTION	VENETIAN BLIND SECTION	