

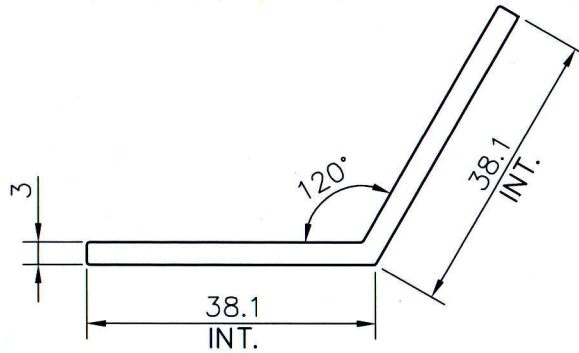

P-JAL-B-240

C-1032



1. STRAIGHTNESS= 1.7mm/M
2. TWIST= 1.7mm/M
3. ANGULARITY= $\pm 2^\circ$
4. FLATNESS= 0.007xWIDTH

(Q00680)

 SYMBOL OF QUALITY AN ISO 9001 COMPANY	JINDAL ALUMINIUM LTD. BHIWADI-301019 (INDIA)	NAME		DATE	
		DRAWN	ASHUTOSH	06-06-2023	
1. ALL DIMENSIONS ARE IN mm. 2. ROUND OFF ALL SHARP CORNERS WITH 0.40 mm. 3. TOLERANCES WILL BE AS PER BS:EN-755-9 , UNLESS OTHERWISE SPECIFIED		CHECKED	<i>Sunil</i>	9/6/23	
		APPROVED	<i>Jha</i>	09/06/23	
		SCALE	1:1		
PARTY'S NAME		K.S.V INFRABUILD, GREATER NOIDA		AREA mm ²	223.27
		PARTY'S DRAWING No.		AS PER DRAWING	PERIMETER mm.
ALLOY & TEMPER		6063-T6		WEIGHT kg/m	0.603
		DESCRIPTION		MISC. ANGLE SECTION	DRAWING No.
				P-JAL-B-240	-
				C-1032	C-1032