

IAL-D-1052

D1052

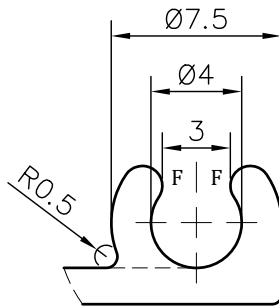
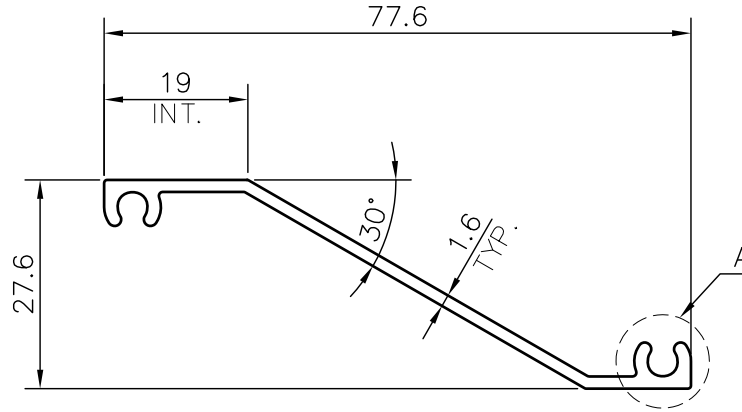

DETAIL-A  
SCALE 3:1

**NOTE:-**

**F= FULL RADIUS (4 PLACES)**

1. STRAIGHTNESS= 1.7mm/M
2. TWIST= 1.7mm/M
3. ANGULARITY=  $\pm 2^\circ$
4. FLATNESS= 0.007xWIDTH

 SYMBOL OF QUALITY AN ISO 9001 COMPANY	<b>JINDAL ALUMINIUM LTD.</b> <i>BHIWADI-301019 (INDIA)</i>		NAME	DATE
			DRAWN	ASHUTOSH
1. ALL DIMENSIONS ARE IN mm. 2. ROUND OFF ALL SHARP CORNERS WITH 0.40 mm. 3. TOLERANCES WILL BE AS PER BS:EN-755-9 , UNLESS OTHERWISE SPECIFIED			CHECKED	
			APPROVED	
PARTY'S NAME T.I.T			SCALE	1:1
			AREA mm <sup>2</sup>	169.06
PARTY'S DRAWING No. AS PER DRAWING			PERIMETER mm.	202.49
			WEIGHT kg/m	0.456
ALLOY & TEMPER 6063 T5			DRAWING No.	SECTION No.
			IAL-D-1052	
DESCRIPTION LOUVER SECTION			D1052	D1052
PRODUCT CODE: -048 HSN CODE: - 76042990				