

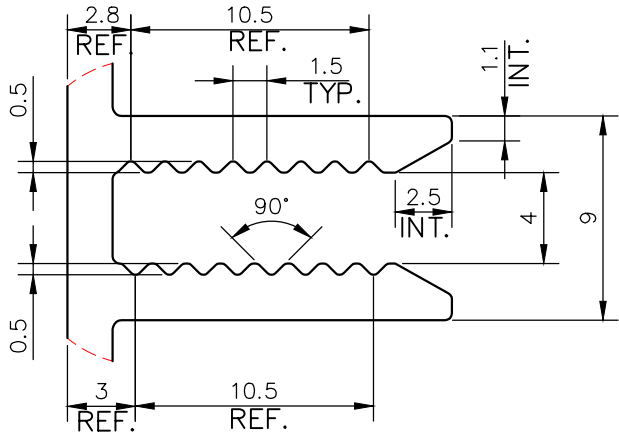

IAL-D-1298
D1298

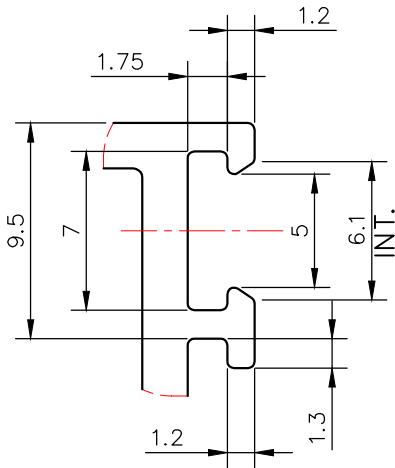
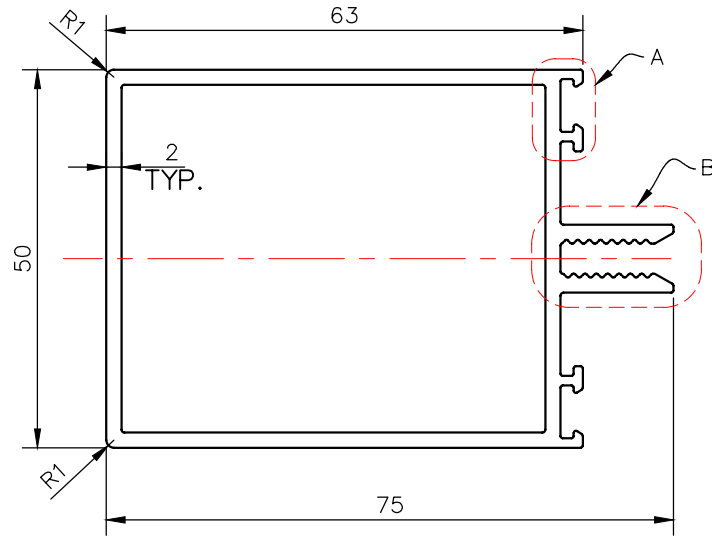

1. TWIST= $1^{\circ}/300$ mm/M
2. STRAIGHTNESS= ± 1.5 mm/M
3. FLATNESS= ± 0.13

 SYMBOL OF QUALITY AN ISO 9001 COMPANY	JINDAL ALUMINIUM LTD. <i>BHIWADI-301019 (INDIA)</i>	NAME	DATE
		DRAWN	ASHUTOSH 29-07-2023
1. ALL DIMENSIONS ARE IN mm. 2. ROUND OFF ALL SHARP CORNERS WITH 0.40 mm. 3. TOLERANCES WILL BE AS PER BS:EN-755-9 , UNLESS OTHERWISE SPECIFIED		CHECKED	
		APPROVED	
PARTY'S NAME WINDOWCRAFT		SCALE	1:1
		AREA mm ²	511.35
PARTY'S DRAWING No. AS PER DRAWING		PERIMETER mm.	314.34
		WEIGHT kg/m	1.381
ALLOY & TEMPER 6063 T5		DRAWING No.	SECTION No.
		IAL-D-1298	
DESCRIPTION CURTAIN WALL SECTION		D1298	D1298