

MAL NO.-14974

D2662

EXPOSED SURFACE



SCALE 1:1

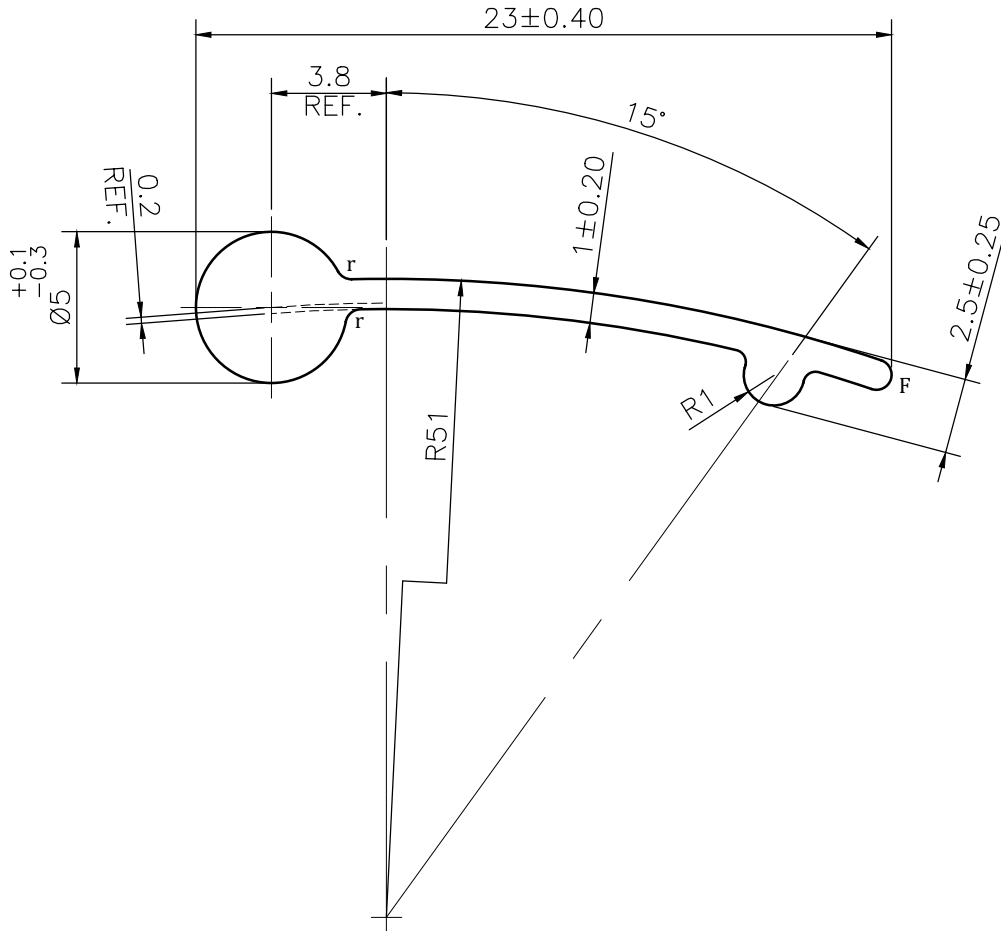

NOTE:-

r= 0.50 RADIUS (2 PLACES)
F= FULL RADIUS (1 PLACE)

1. STRAIGHTNESS= 1.7mm/M
2. TWIST= 1.7mm/M
3. ANGULARITY= ±2°
4. FLATNESS= 0.007xWIDTH



SYMBOL OF QUALITY
AN ISO 9001 COMPANY

JINDAL ALUMINIUM LTD.
 BANGALORE-560073 (INDIA)

	NAME	DATE
DRAWN	ASHUTOSH	24-08-2023
CHECKED		
APPROVED		
SCALE		4:1
AREA mm ²		40.564
PERIMETER mm.		53.55
WEIGHT kg/m		0.11
DRAWING No.	SECTION No.	
MAL NO.-14974	-	
D2662	D2662	

1. ALL DIMENSIONS ARE IN mm.
2. ROUND OFF ALL SHARP CORNERS WITH 0.40 mm.
3. TOLERANCES WILL BE AS PER BS:EN-755-9 , UNLESS OTHERWISE SPECIFIED

PARTY'S NAME	RUSKIN TITUS	
PARTY'S DRAWING No.	AS PER DRAWING	
ALLOY & TEMPER	6063 T6	PRODUCT CODE:-082
		HSN CODE:- 76042990
DESCRIPTION	AIR GRILL SECTION	