

MAL NO-5247

D2697

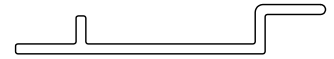
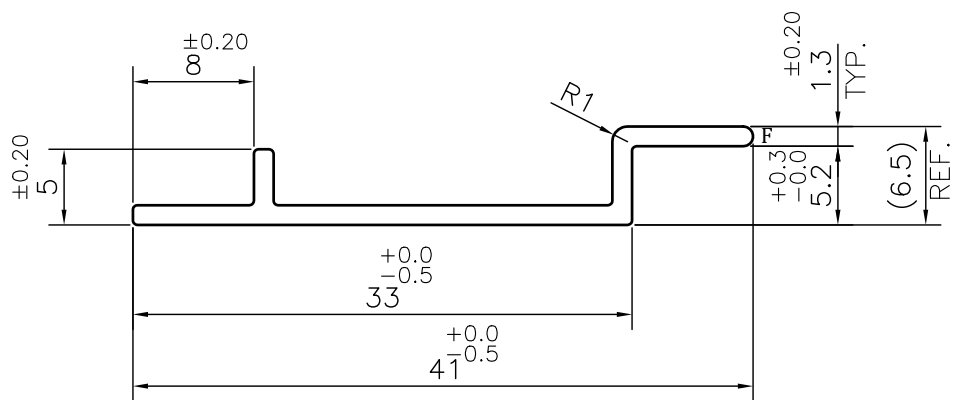

SCALE 1:1

**NOTE:-****F= FULL RADIUS (1 PLACE)**

1. STRAIGHTNESS= 1.7mm/M
2. TWIST= 1.7mm/M
3. ANGULARITY= ±2°
4. FLATNESS= 0.007xWIDTH



SYMBOL OF QUALITY  
AN ISO 9001 COMPANY

**JINDAL ALUMINIUM LTD.**  
BHIWADI-301019 (INDIA)

	NAME	DATE
DRAWN	ASHUTOSH	07-10-2023

CHECKED		
APPROVED		

1. ALL DIMENSIONS ARE IN mm.
2. ROUND OFF ALL SHARP CORNERS WITH 0.40 mm.
3. TOLERANCES WILL BE AS PER BS:EN-755-9 , UNLESS OTHERWISE SPECIFIED

SCALE	2:1
-------	-----

AREA mm <sup>2</sup>	64.455
----------------------	--------

PERIMETER mm.	100.25
---------------	--------

WEIGHT kg/m	0.174
-------------	-------

PARTY'S NAME	RAVISTAR PVT. LTD.
--------------	--------------------

DRAWING No.	SECTION No.
MAL NO-5247	-
D2697	D2697

PARTY'S DRAWING No.	AS PER DRAWING
---------------------	----------------

ALLOY & TEMPER	6063 T6	PRODUCT CODE:-082
		HSN CODE:- 76042990

DESCRIPTION	AIR GRILL SECTION
-------------	-------------------