

MAL-5248

D2698

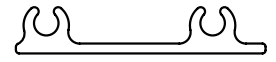
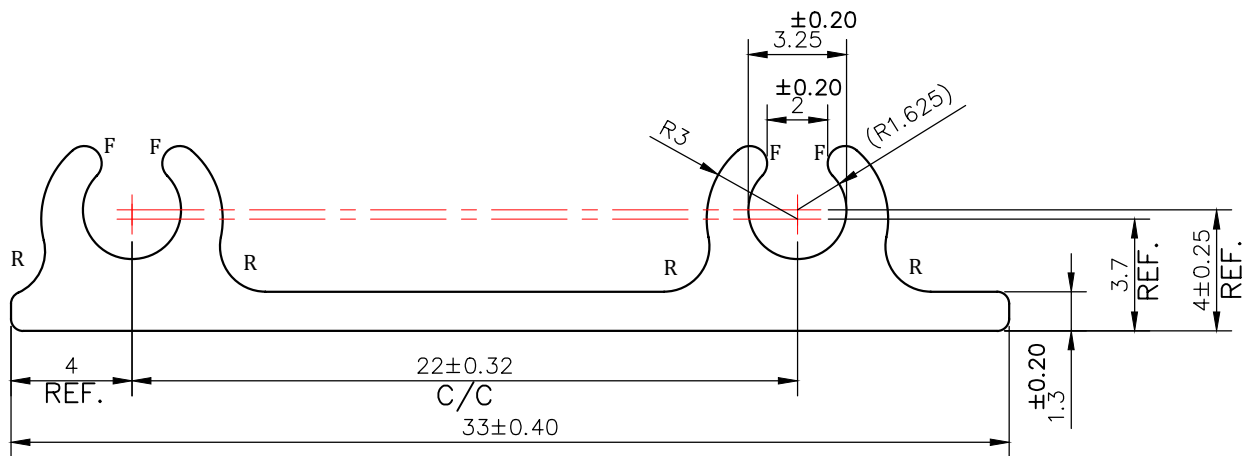

SCALE 1:1

**NOTE:-**

**R= 1.5 RADIUS (4 PLACES)**  
**F= FULL RADIUS (4 PLACES)**

1. TWIST=  $1^{\circ}/300$  mm/M
2. STRAIGHTNESS=  $\pm 1.5$  mm/M
3. FLATNESS=  $\pm 0.13$



SYMBOL OF QUALITY  
AN ISO 9001 COMPANY

**JINDAL ALUMINIUM LTD.**  
 BHIWADI-301019 (INDIA)

	NAME	DATE
DRAWN	ASHUTOSH	29-07-2023

CHECKED		
APPROVED		

SCALE	4:1
-------	-----

AREA mm <sup>2</sup>	78.69
----------------------	-------

PERIMETER mm.	96.13
---------------	-------

WEIGHT kg/m	0.212
-------------	-------

DRAWING No.	SECTION No.
MAL-5248	
D2698	D2698

--	--

--	--

--	--

1. ALL DIMENSIONS ARE IN mm.
2. ROUND OFF ALL SHARP CORNERS WITH 0.40 mm.
3. TOLERANCES WILL BE AS PER BS:EN-755-9, UNLESS OTHERWISE SPECIFIED

PARTY'S NAME	RAVISTAR INDIA PVT. LTD.
--------------	--------------------------

PARTY'S DRAWING No.	AS PER DRAWING
---------------------	----------------

ALLOY & TEMPER	6063	PRODUCT CODE: -082
		HSN CODE: -76042990

DESCRIPTION	AIR GRILL SECTION
-------------	-------------------