

MAL-5249

D2699

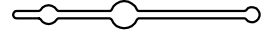
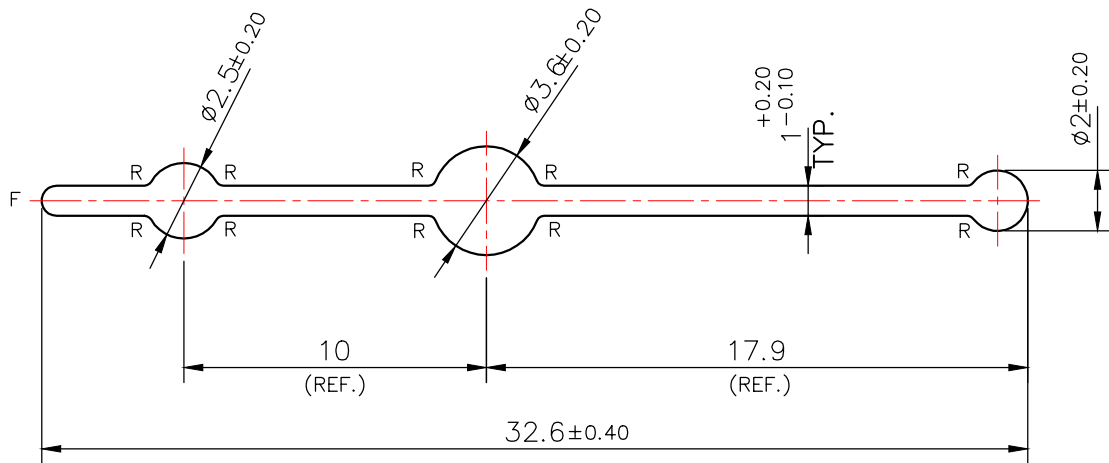

SCALE 1:1

**NOTE:-**

R= 0.25 RADIUS (10 PLACES)
F= FULL RADIUS (1 PLACE)

1. TWIST= 1/4°/300 mm/M
2. STRAIGHTNESS= 1.5 mm/M
3. ANGULARITY= ±2°



SYMBOL OF QUALITY
AN ISO 9001 COMPANY

JINDAL ALUMINIUM LTD.
 BHIWADI-301019 (INDIA)

	NAME	DATE
DRAWN	AMIT	31-05-2023
CHECKED		
APPROVED		

SCALE	1:1 & 4:1
AREA mm ²	42.823
PERIMETER mm.	70.50
WEIGHT kg/m	0.116
DRAWING No.	SECTION No.
MAL-5249	
D2699	D2699

1. ALL DIMENSIONS ARE IN mm.
2. ROUND OFF ALL SHARP CORNERS WITH 0.40 mm.
3. TOLERANCES WILL BE AS PER BS:EN-755-9 , UNLESS OTHERWISE SPECIFIED

PARTY'S NAME	RAVISTAR INDIA PVT. LTD.
PARTY'S DRAWING No.	AS PER DRAWING
ALLOY & TEMPER	6063
DESCRIPTION	AIR GRILL SECTION