

MAL-5305

D2720

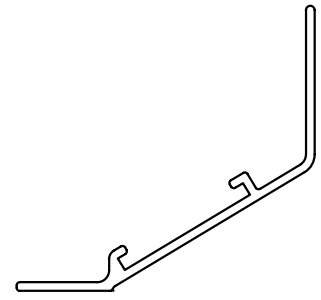
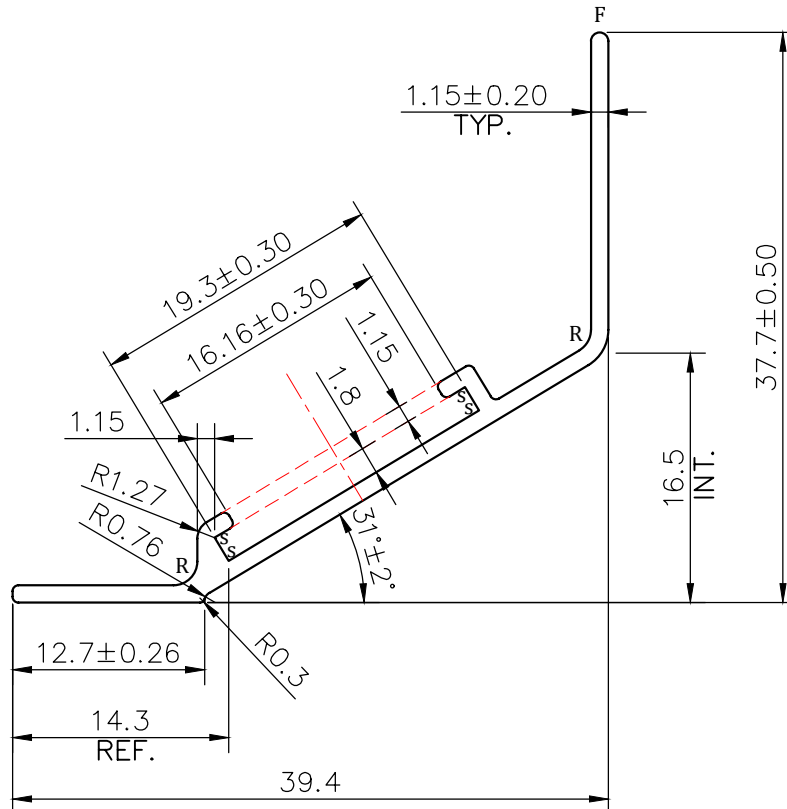

SCALE 1:1

**NOTE:-**

- R= 1.57 RADIUS (2 PLACES)**
F= FULL RADIUS (1 PLACE)
s= SHARP CORNER (4 PLACES)

1. STRAIGHTNESS= 1.7mm/M
2. TWIST= 1.7mm/M
3. ANGULARITY= $\pm 2^\circ$
4. FLATNESS= 0.007xWIDTH



SYMBOL OF QUALITY
AN ISO 9001 COMPANY

JINDAL ALUMINIUM LTD.
BHIWADI-301019 (INDIA)

	NAME	DATE
DRAWN	ASHUTOSH	29-07-2023
CHECKED		
APPROVED		

1. ALL DIMENSIONS ARE IN mm.
2. ROUND OFF ALL SHARP CORNERS WITH 0.40 mm.
3. TOLERANCES WILL BE AS PER BS:EN-755-9, UNLESS OTHERWISE SPECIFIED

PARTY'S NAME	RAVISTAR INDIA PVT. LTD.	
PARTY'S DRAWING No.	AS PER DRAWING	
ALLOY & TEMPER	6063	PRODUCT CODE: -082 HSN CODE: -76042990
DESCRIPTION	AIR GRILL SECTION	

SCALE 2:1

AREA mm² 85.29

PERIMETER mm. 144.81

WEIGHT kg/m 0.230

DRAWING No. SECTION No.

MAL-5305

D2720

D2720