

MAL NO.-5523

D2884

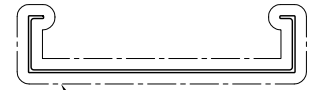

EXPOSED SURFACE

SCALE 1:4

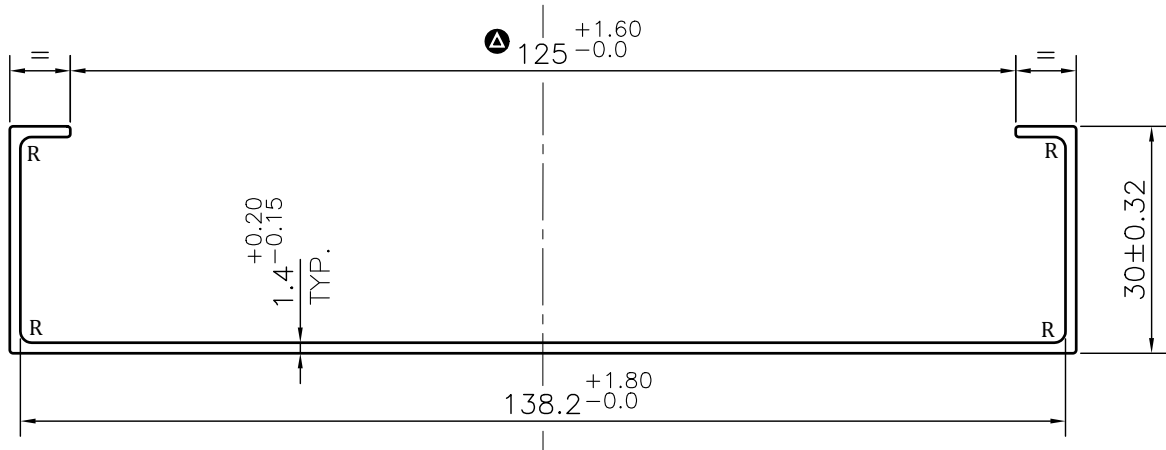
ISSUE-2 Δ (14-05-2024)* TOLERANCE CHANGED FROM $125^{+1.60}_{-1.0}$ TO $125^{+1.60}_{-0}$ **NOTE:-****R= 1.50 RADIUS (4 PLACES)**

1. STRAIGHTNESS= 1.7mm/M
2. TWIST= 1.7mm/M
3. ANGULARITY= $\pm 2^\circ$
4. FLATNESS= 0.007xWIDTH

SYMBOL OF QUALITY
AN ISO 9001 COMPANY**JINDAL ALUMINIUM LTD.**
BHIWADI-301019 (INDIA)

	NAME	DATE
DRAWN	ASHUTOSH	14-05-2024
CHECKED		
APPROVED		

SCALE

1:1

AREA mm²

297.617

PERIMETER mm.

421.65

WEIGHT kg/m

0.804

DRAWING No.

SECTION No.

PARTY'S NAME SYSTEMAIR INDIA PVT. LTD.

PARTY'S DRAWING No. AS PER DRAWING-620E-4636(R)

ALLOY & TEMPER 6063

PRODUCT CODE:-082

HSN CODE:- 76042990

DESCRIPTION

AIR GRILL SECTION-(VOLUME CONTROL DAMPER)

MAL NO.-5523

-

D2884-ISSUE-2

D2884