

WT. RANGE: 3.66 TO 3.80 Kg/12'

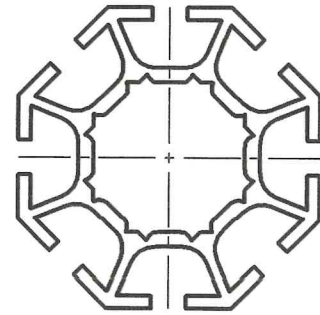

ACTUAL SIZE

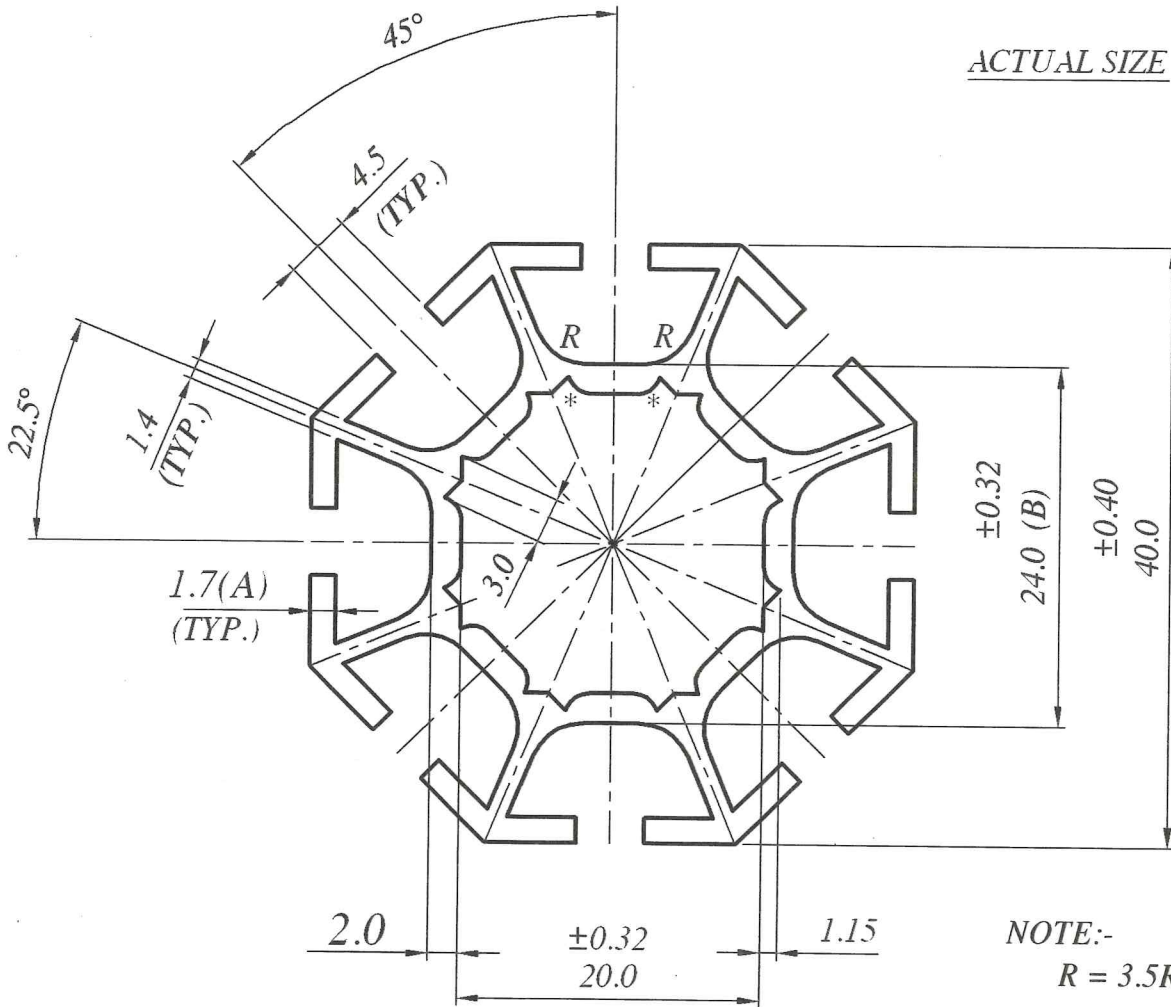

NOTE:-

R = 3.5R

\* = 1.5R

LOCATION:- P1-1HOLE

ALL DIMENSION ARE IN M.M.  
UNSPECIFIED CORNER RADIUS:0.40

TOL. AS PER B.S.1474:1987  
UNLESS SPECIFIED

TWIST = 1/4°/300 M.M./M.

STRAIGHTNESS= 1.5 M.M./MTR.

ANGULARITY = 2°

**INDO ALUSYS INDUSTRIES LIMITED BHIWADI RAJSTHAN-301019**

PARTY SAMPLE & DRG.		SAMPLE		PARTY NAME M/s. RAM AVTAR & CO.		REF:- MKT-11/R-11/98-99/5879/18.3.99	
				DRAWN S.K.SHARMA	21.12.05	AREA:	375.0 MM <sup>2</sup>
				CHECKED	22.12.05	WEIGHT:	1.013 KG/M.
	(B)	DIM.24.0 WAS 25.0mm.		APPROVED	22.12.05	WT. RANGE:	3.66 TO 3.80 Kg/12'
	(A)	DIM.1.7 WAS 2.0mm.		SCALE	1:1&2:1	DATE	
001	REF.	AS PER JOB ORDER DT.15.12.05		CRITICAL DIM.	*	ALLOY:	6063
REV. STATUS	REV. NO.	DESCRIPTION	SIGN DATE	PERIMETER	INT. 82.5	MAL.No.	5748
		REVISION			EXT. 364.5	SEC.NO.	D-2951