

MAL NO-9452  
D3989

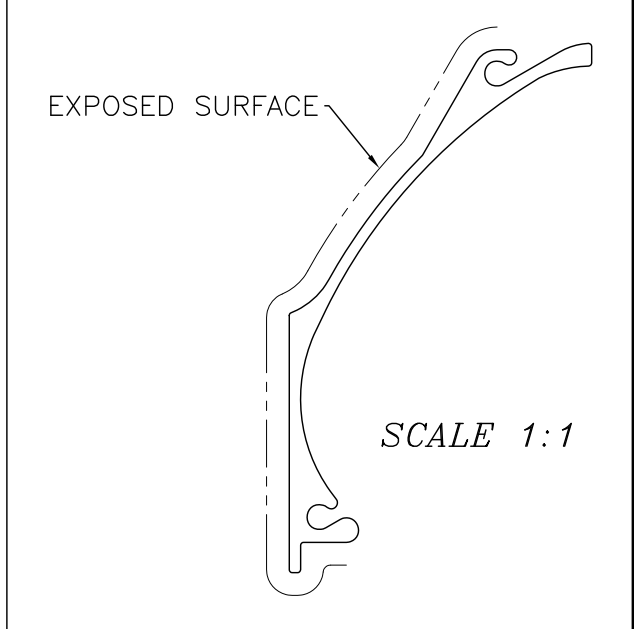
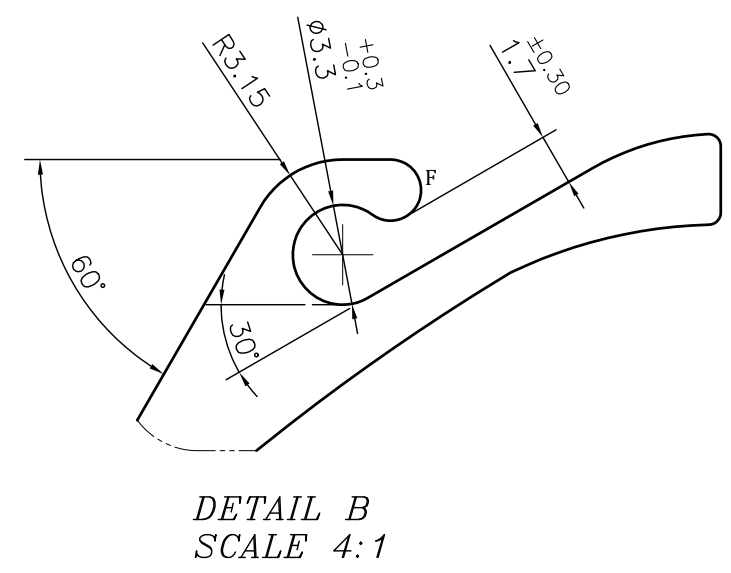
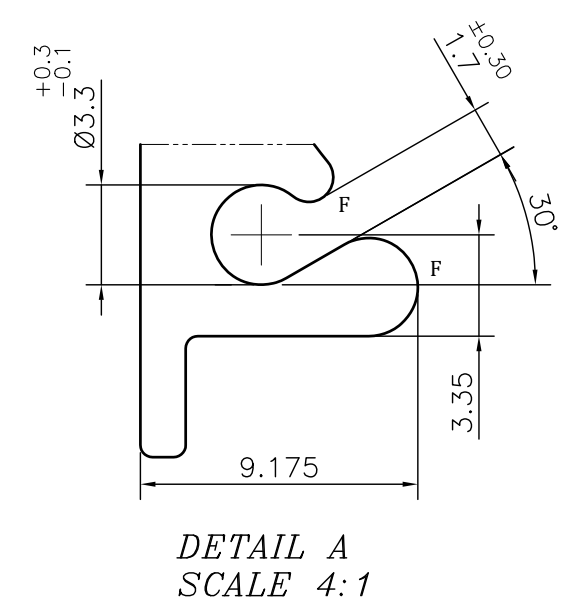
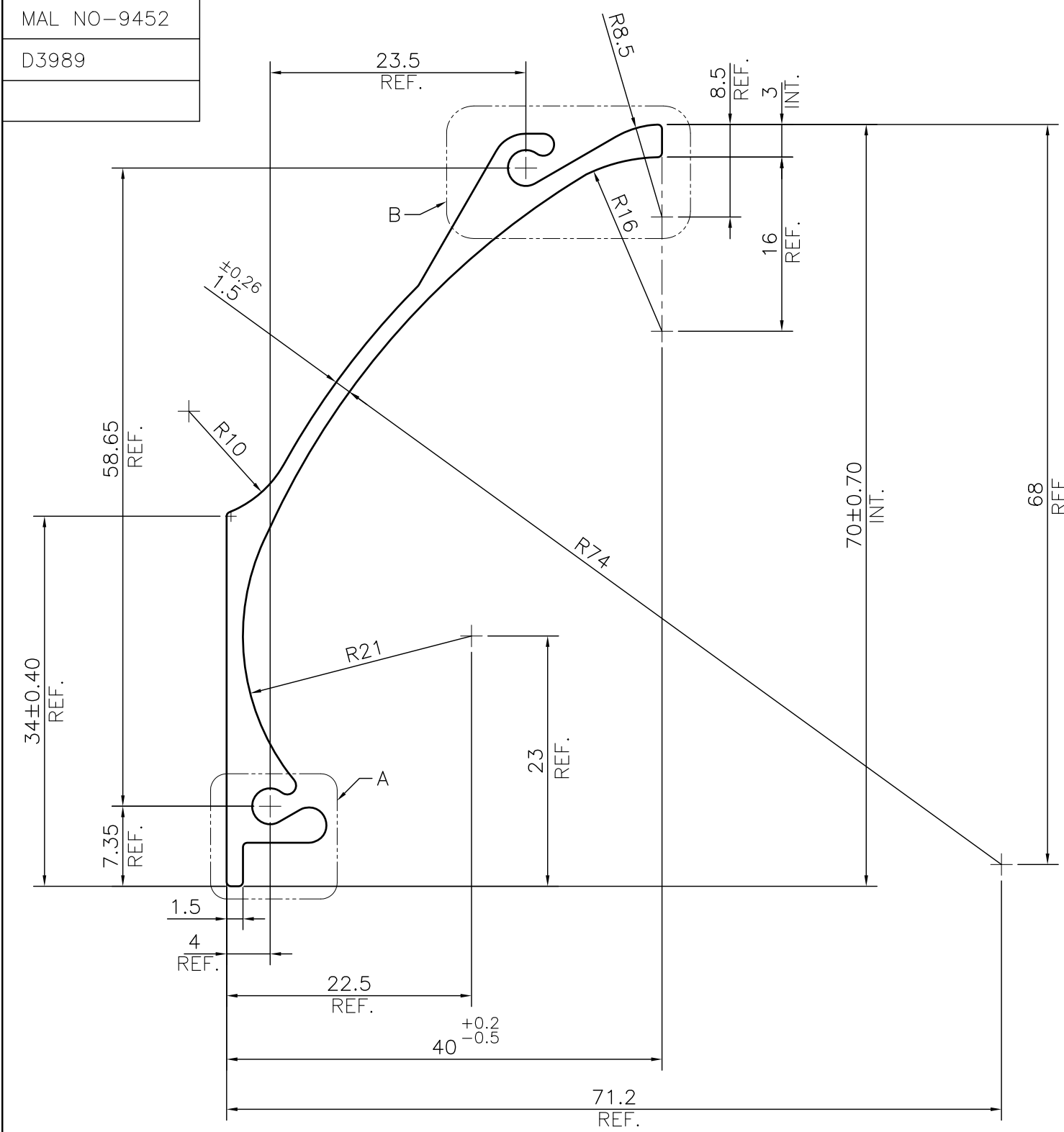

**NOTE:-**  
**F= FULL RADIUS (3 PLACES)**

1. STRAIGHTNESS= 1.7mm/M
2. TWIST= 1.7mm/M
3. ANGULARITY= ±2°
4. FLATNESS= 0.007xWIDTH

<p>SYMBOL OF QUALITY AN ISO 9001 COMPANY</p>	<p><b>JINDAL ALUMINIUM LTD.</b> BHIWADI-301019 (INDIA)</p>	NAME	DATE
		DRAWN	ASHUTOSH 29-09-2023
<p>1. ALL DIMENSIONS ARE IN mm. 2. ROUND OFF ALL SHARP CORNERS WITH 0.40 mm. 3. TOLERANCES WILL BE AS PER BS:EN-755-9 , UNLESS OTHERWISE SPECIFIED</p>		CHECKED	
		APPROVED	
<p>PARTY'S NAME RAVISTAR INDIA PVT. LTD.</p>		SCALE	2:1
		AREA mm <sup>2</sup>	234.685
<p>PARTY'S DRAWING No. AS PER DRAWING</p>		PERIMETER mm.	212.54
		WEIGHT kg/m	0.634
<p>ALLOY &amp; TEMPER 6063 T6</p>		DRAWING No.	SECTION No.
		MAL NO-9452	-
<p>DESCRIPTION AIR GRILL SECTION</p>		D3989	D3989
		PRODUCT CODE:-082	
		HSN CODE:- 76042990	