

MAL NO.-10269

D4363

EXPOSED SURFACE

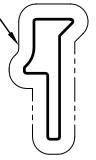

SCALE 1:1

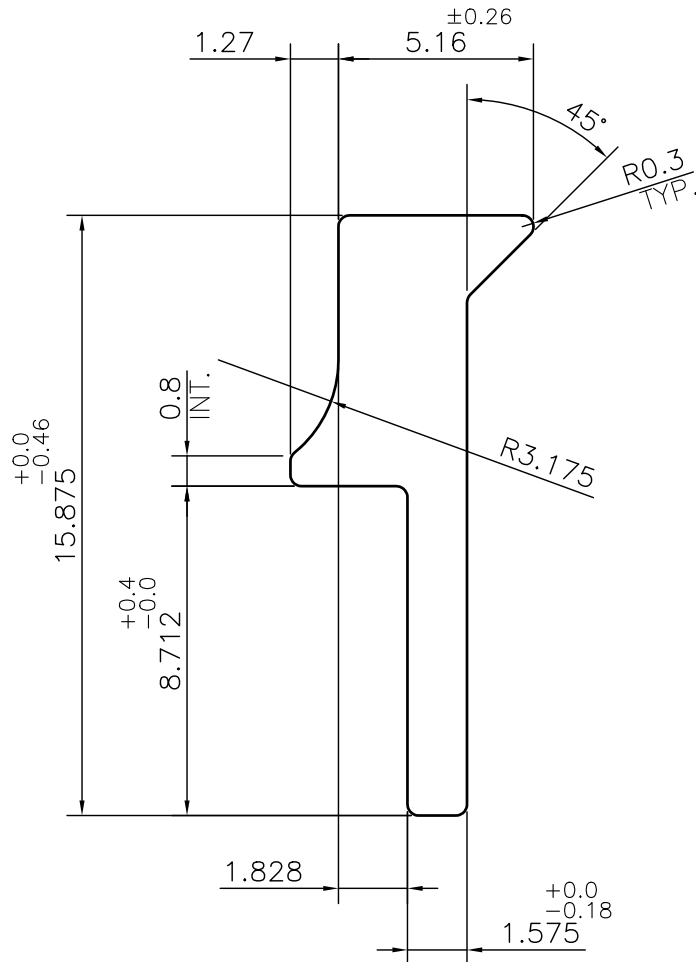

☞ ROUND OFF ALL SHARP CORNERS WITH 0.30 mm.

1. STRAIGHTNESS= 1.7mm/M
2. TWIST= 1.7mm/M
3. ANGULARITY=  $\pm 2^\circ$
4. FLATNESS= 0.007xWIDTH



SYMBOL OF QUALITY  
AN ISO 9001 COMPANY

**JINDAL ALUMINIUM LTD.**  
BANGALORE-560073 (INDIA)

	NAME	DATE
DRAWN	ASHUTOSH	XX-0X-2023
CHECKED		
APPROVED		

1. ALL DIMENSIONS ARE IN mm.
2. ROUND OFF ALL SHARP CORNERS WITH 0.40 mm.
3. TOLERANCES WILL BE AS PER BS:EN-755-9 , UNLESS OTHERWISE SPECIFIED

SCALE	5:1
AREA mm <sup>2</sup>	42.293
PERIMETER mm.	41.9
WEIGHT kg/m	0.114

PARTY'S NAME	CARYAIRE	DRAWING No.	SECTION No.
PARTY'S DRAWING No.	AS PER DRAWING	MAL NO.-10269	-
ALLOY & TEMPER	6063 T5	D4363	D4363
DESCRIPTION	AIR GRILL SECTION	PRODUCT CODE:-082	
		HSN CODE:- 76042990	