

DETAIL AT-A

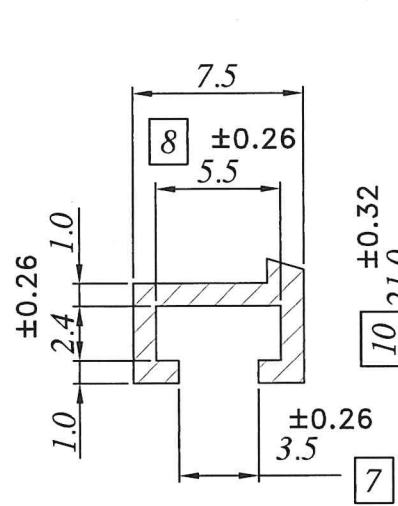

DETAIL AT-C

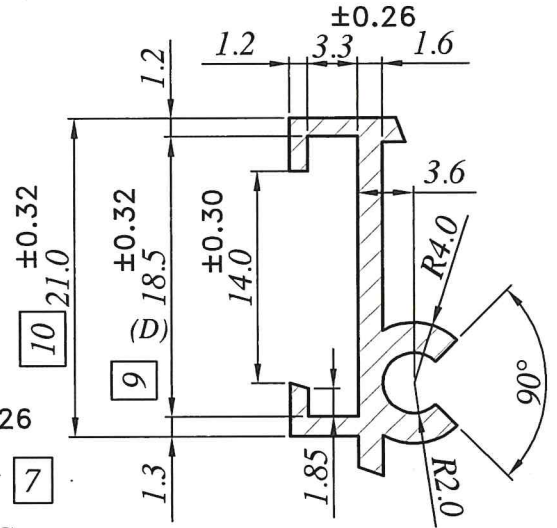

DETAIL AT-B

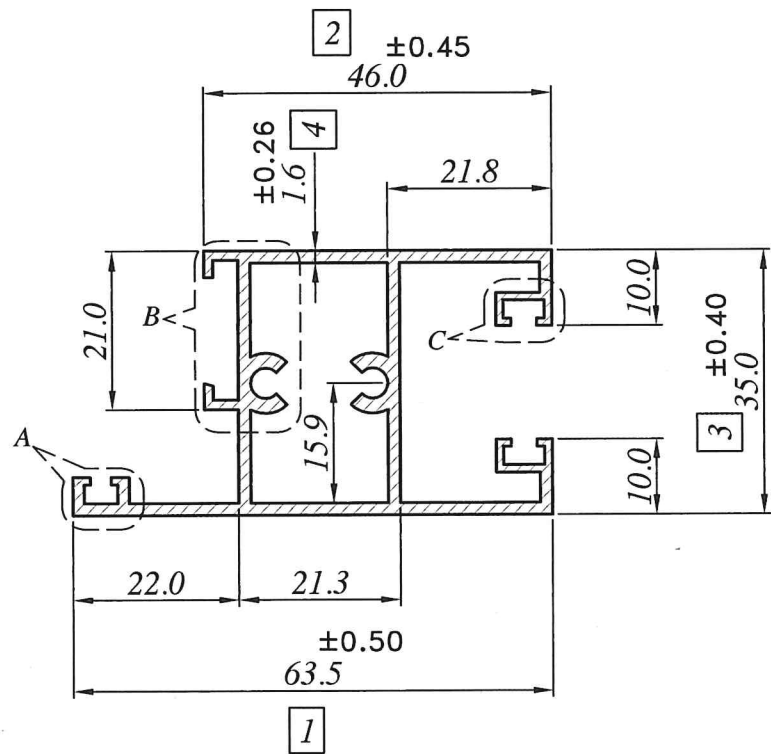

DIE NO:- D-3899

LOCATION: P2 - 1HOLE
 ALL DIMENSION ARE IN M.M.
 UNSPECIFIED CORNER RADIUS:0.40

TOL. AS PER B.S.1474:1987
 UNLESS SPECIFIED

TWIST = 1/4°/300M.M.M.
 STRAIGHTNESS = 1.5 M.M./MTR.
 ANGULARITY = ±2°

INDO ALUSYS INDUSTRIES LIMITED BHIWADI RAJASTHAN - 301019

PARTY SAMPLE & DRG. DRG. No.-SD4A		PARTY NAME M/S UNIBUILD			REF:-MKT-22/U-10/2001/634 Dt-01.10.07			
(D)	DIM.18.5 WAS 18.1		DRAWN	DHARMVIR	19.10.07	AREA	384.00	MM ²
(C)	DIM.2.8 WAS 2.5		CHECKED		15-2-02	WEIGHT	1.037	KG/M.
(B)	DIM.2.5 WAS 1.8		APPROVED		15-2-02	WT. RANGE	-----	Kg/12'
(A)	DIM.4.5 WAS 4.3		SCALE	1:1.2:1&3:1	DATE	ALLOY	6063	
001	(REF.) AS PER IOM LETTER Dt-27.12.07		CRITICAL DIM. *			MAL NO	10252	
REV. STATUS	REV. NO.	DESCRIPTION	SIGN DATE	PERIMETER	INT.	133.81	SEC.NO.	D-4386