

DETAIL AT- A

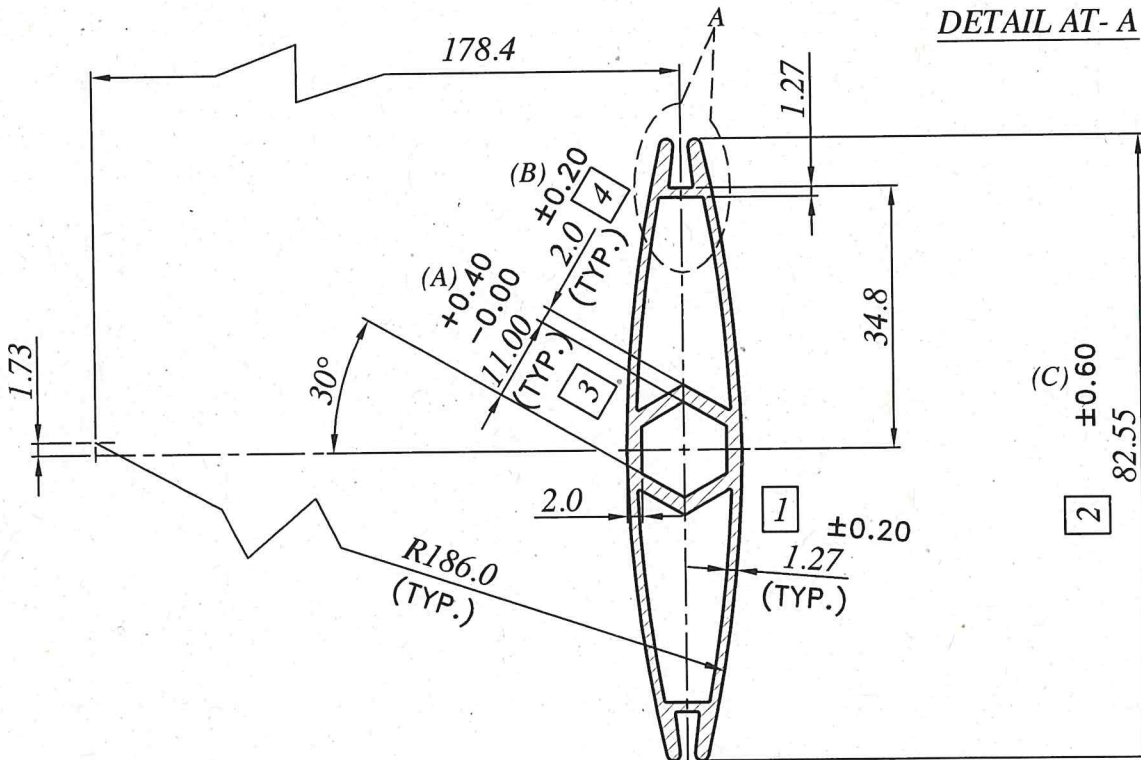

LOCATION:- P2 - 1HOLE
 ALL DIMENSION ARE IN M.M.
 UNSPECIFIED CORNER RADIUS:0.40

TOL. AS PER B.S.1474:1987
 UNLESS SPECIFIED

TWIST = 1/4°/300M.M.M.
 STRAIGHTNESS = 1.5 M.M./MTR.
 ANGULARITY = ±2°

INDO ALUSYS INDUSTRIES LIMITED BHIWADI RAJASTHAN - 301019

PARTY SAMPLE & DRG. 70-003810-00B		PARTY NAME M/S CARYAIRE NOIDA		REF:-AS PER EMAIL Dt-07.03.08			
(C)	TOL.±0.60 WAS ±0.65	DRAWN	DHARMVIR	12.03.08	AREA	310.00	MM ²
(B)	TOL.±0.20 WAS ±0.26	CHECKED	<i>[Signature]</i>	6.6.08	WEIGHT	0.837	KG/M.
(A)	TOL.+0.40 WAS +0.50 -0.00 -0.00	APPROVED	<i>[Signature]</i>	6.6.08	WT. RANGE	-----	Kg/12'
		SCALE	1:1&3:1	DATE	ALLOY	6063-T5	
00	(REF.) AS PER PARTY EMAIL DT-04.04.08	CRITICAL DIM. *			MAL NO	10481	
REV. STATUS	REV. NO.	DESCRIPTION	SIGN DATE	PERIMETER	INT.	191.60	SEC.NO. D-4468
				EXT.	202.50		