

Kind Attn: Mr. B.K. Srivastava,

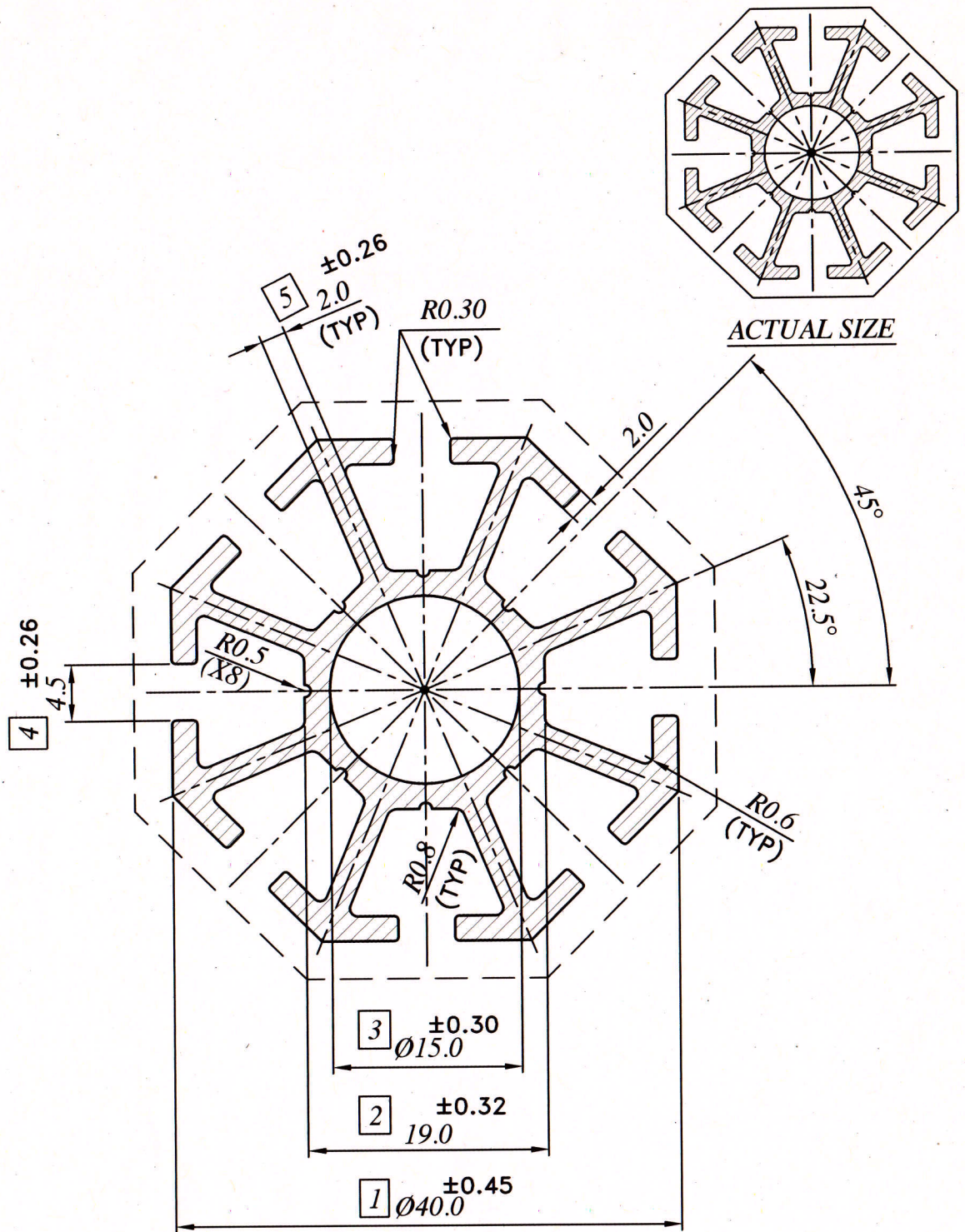

LOCATION:- P2 - 1HOLE  
 ALL DIMENSION ARE IN M.M.  
 UNSPECIFIED CORNER RADIUS:0.40

TOL. AS PER B.S.1474:1987  
 UNLESS SPECIFIED

TWIST = 1/4°/300 M.M./M.  
 STRAIGHTNESS= 1.5 M.M./MTR.  
 ANGULARITY = 2°

## JINDAL ALUMINIUM LTD., BHIWADI - 301019

PARTY NAME M/S MEROFORM INDIA		REF:- AS PER EMAIL DT-13.05.08	
DRW	DRG.	DRAWN DHARMVIR	16.05.08
		CHECKED <i>SSZ</i>	8.6.08
		APPROVED <i>SSZ</i>	6.6.08
		SCALE 1:1&2:1	DATE
OO	(REV.)	CRITICAL DIM. *	
REV. STATUS	REV. NO.	DESCRIPTION	SIGN DATE
		REVISION	
		PERIMETER	INT. 47.10 EXT. 375.90
		AREA: 449.50	MM <sup>2</sup>
		WEIGHT: 1.214	KG/M.
		WT. RANGE: -----	Kg/12'
		ALLOY: 6063-T6	
		MAL.No. 10583	
		SEC.NO. D-4475	