

DETAIL AT- A

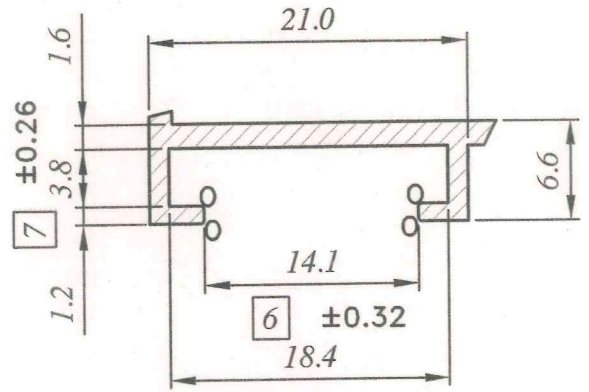

DETAIL AT- B

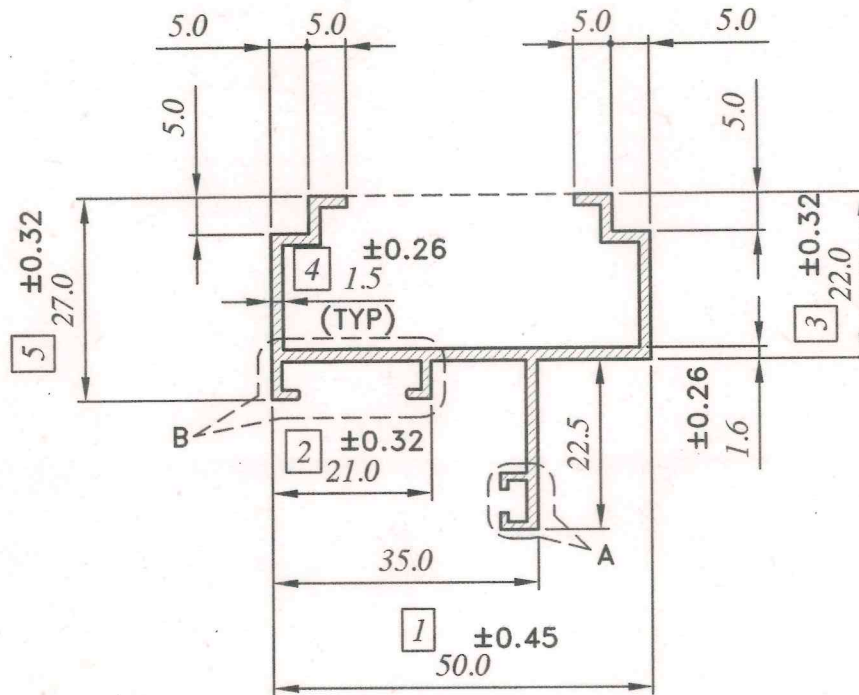

NOTE:-

0 = 0.25R

LOCATION:-P1 - 2HOLE  
 ALL DIMENSION ARE IN M.M.  
 UNSPECIFIED CORNER RADIUS:0.40

TOL. AS PER B.S.1474:1987  
 UNLESS SPECIFIED

TWIST = 1/4°/300M.M.M.  
 STRAIGHTNESS = 1.5 M.M./MTR.  
 ANGULARITY = ±2°

**INDO ALUSYS INDUSTRIES LIMITED BHIWADI RAJASTHAN - 301019**

PARTY SAMPLE & DRG. F 1 A			PARTY NAME M/S AAP DIVISION			REF:-AS PER IOM LETTER Dt-19.08.08		
			DRAWN	DHARMVIR	25.08.08	AREA	228.00	MM <sup>2</sup>
			CHECKED	<i>[Signature]</i>	23.10.08	WEIGHT	0.616	KG/M.
			APPROVED	<i>[Signature]</i>	23.10.08	WT. RANGE	-----	Kg/12'
			SCALE	1:1,2:1&3:1	DATE	ALLOY	6063-T6	
00	(REF.)		CRITICAL DIM. *			MAL NO	10718	
REV. STATUS	REV. NO.	DESCRIPTION	SIGN DATE	PERIMETER	INT.	-----	SEC.NO.	D-4518
		REVISION			EXT.	310.70		