

DETAIL AT- A

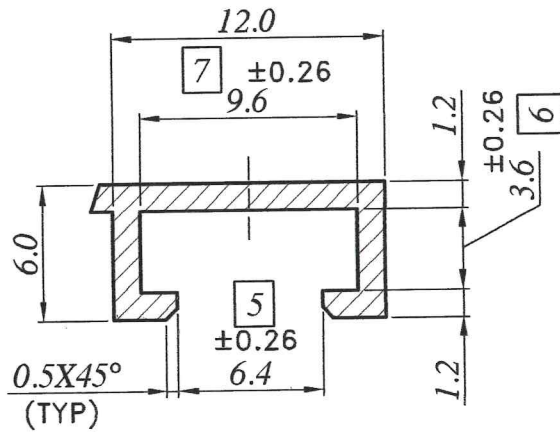

DETAIL AT- B

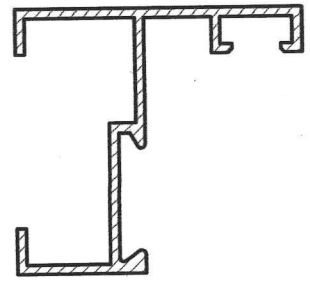

ACTUAL SIZE

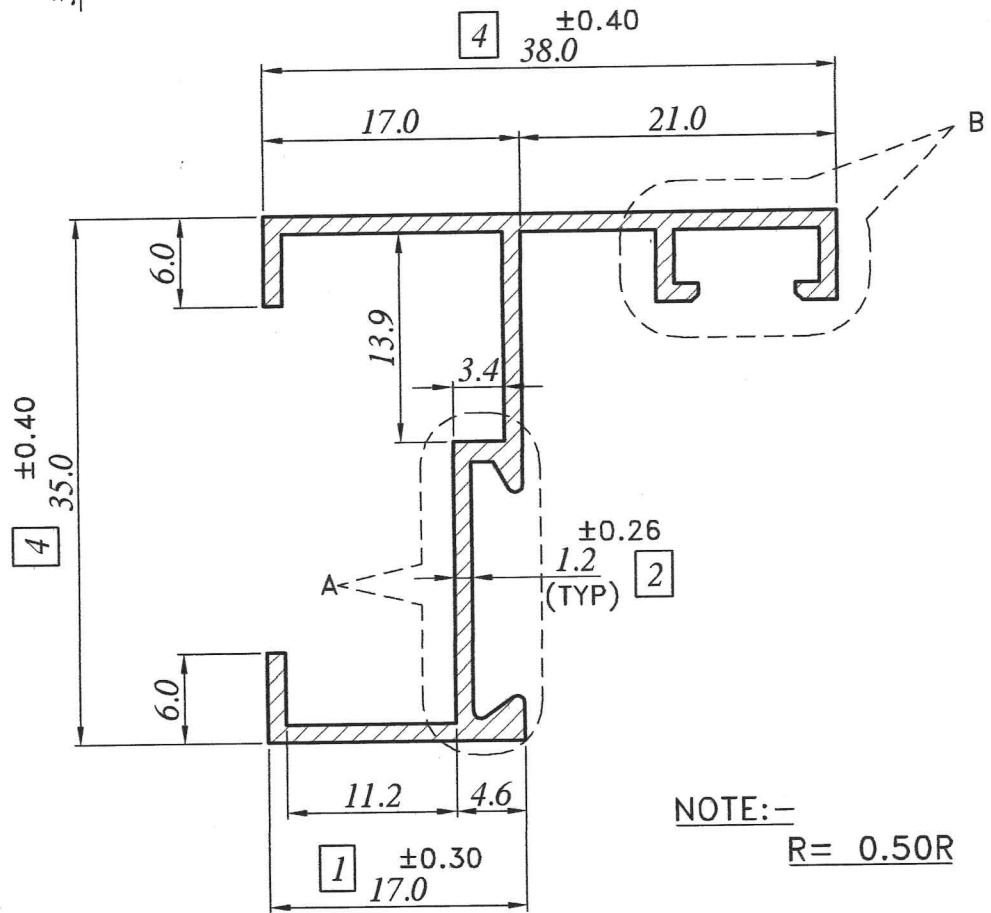

NOTE:-
R = 0.50R

LOCATION:-P1 - 2HOLE
ALL DIMENSION ARE IN M.M.
UNSPECIFIED CORNER RADIUS:0.40

TOL. AS PER B.S.1474:1987
UNLESS SPECIFIED

TWIST = 1/4°/300M.M.M.
STRAIGHTNESS = 1.5 M.M./MTR.
ANGULARITY = ±2°

INDO ALUSYS INDUSTRIES LIMITED BHIWADI RAJASTHAN - 301019

PARTY SAMPLE & DRG.		BTAL-53		PARTY NAME M/S BESTECH			REF:-AS PER DRG. Dt-16.12.08	
				DRAWN	DHARMVIR	17.12.08	AREA	142.70 MM ²
				CHECKED	<i>[Signature]</i>	7.1.09	WEIGHT	0.386 KG/M.
				APPROVED	<i>[Signature]</i>	7.1.09	WT. RANGE	----- Kg/12'
				SCALE	1:1,2:1&3:1	DATE	ALLOY	6063-T6
00	(REF.)			CRITICAL DIM. *			MAL NO	10872
REV. STATUS	REV. NO.	DESCRIPTION	SIGN DATE	PERIMETER	INT.	-----	SEC.NO.	D-4553
		REVISION			EXT.	233.00		