

MAL NO-10889

D4565

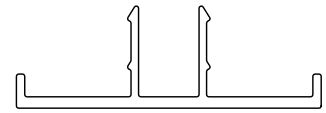

SCALE 1:1

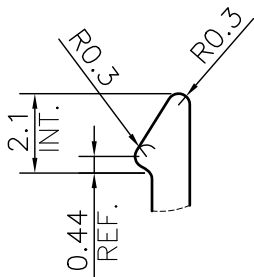
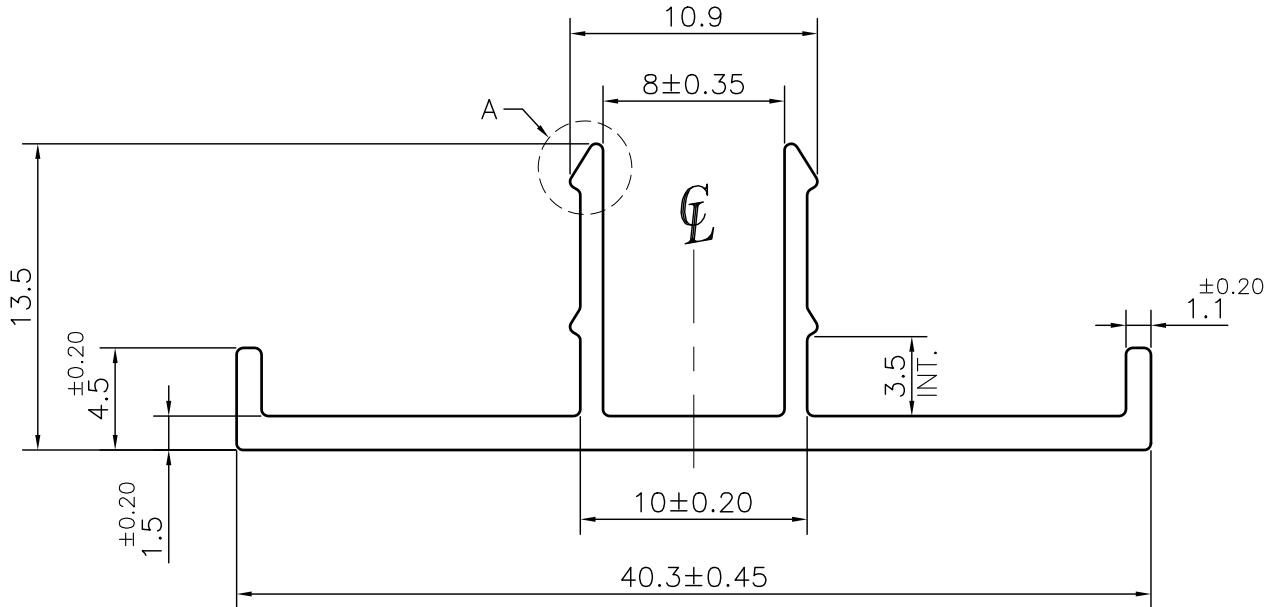

☞ ROUND OFF ALL SHARP CORNERS WITH 0.30 mm.

DETAIL A
SCALE 5:1

1. STRAIGHTNESS= 1.7mm/M
2. TWIST= 1.7mm/M
3. ANGULARITY= $\pm 2^\circ$
4. FLATNESS= 0.007xWIDTH



SYMBOL OF QUALITY
AN ISO 9001 COMPANY

JINDAL ALUMINIUM LTD.
BHIWADI-301019 (INDIA)

	NAME	DATE
DRAWN	ASHUTOSH	10-10-2023
CHECKED		
APPROVED		
SCALE		2:1
AREA mm ²		91.897
PERIMETER mm.		142.24
WEIGHT kg/m		0.248
DRAWING No.	SECTION No.	
MAL NO-10889	-	
D4565	D4565	

1. ALL DIMENSIONS ARE IN mm.
2. ROUND OFF ALL SHARP CORNERS WITH 0.40 mm.
3. TOLERANCES WILL BE AS PER BS:EN-755-9 , UNLESS OTHERWISE SPECIFIED

PARTY'S NAME	S.M.W	
PARTY'S DRAWING No.	AS PER DRAWING	
ALLOY & TEMPER	6063 T6	PRODUCT CODE:-085 HSN CODE:- 76042990
DESCRIPTION	INDUSTRIAL SECTION	