

MAL-10971

D4631

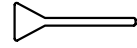

SCALE 1:1

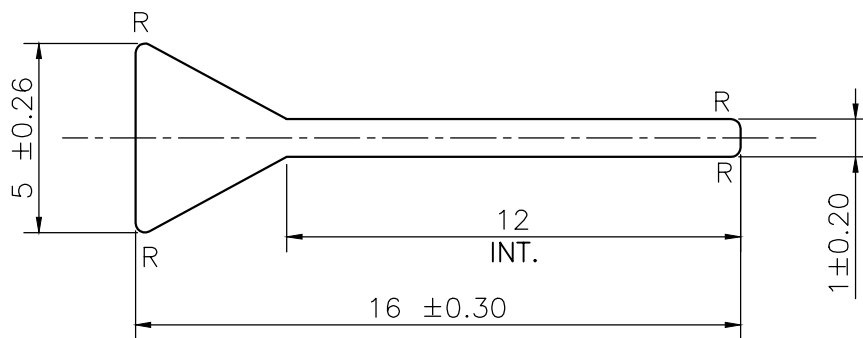

**NOTE:-**  
**R= 0.25 RADIUS (4 PLACES)**

TWIST=  $\pm 1/4^\circ/300\text{M.M./M.}$ 

STRAIGHTNESS= 1.5 M.M./MTR.

ANGULARITY=  $\pm 1.5^\circ$ 

SYMBOL OF QUALITY  
 AN ISO 9001 COMPANY

**JINDAL ALUMINIUM LTD.**  
 BANGALORE-560073 (INDIA)

	NAME	DATE
DRAWN	ASHUTOSH	23-05-2022
CHECKED		
APPROVED		

1. ALL DIMENSIONS ARE IN mm.
2. ROUND OFF ALL SHARP CORNERS WITH 0.40 mm.
3. TOLERANCES WILL BE AS PER BS.S.1474:1987 , UNLESS OTHERWISE SPECIFIED

SCALE	1:1 & 5:1
AREA mm <sup>2</sup>	24.60
PERIMETER mm.	38.60
WEIGHT kg/m	0.066

PARTY'S NAME	M/S. RAVISTAR INDIA PVT. LTD.	DRAWING No.	SECTION No.
PARTY'S DRAWING No.	AS PER DRAWING	MAL-10971	
ALLOY & TEMPER	6063 T6	D4631	D4631
DESCRIPTION	AIR GRILL SECTION		