

DETAIL AT- A

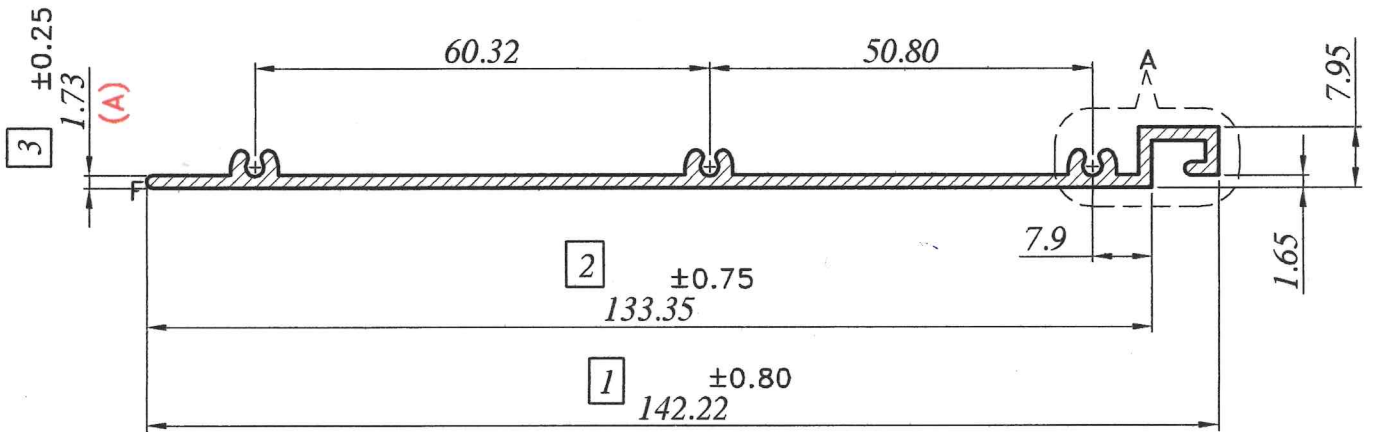

NOTE:-

F= Full Radius

LOCATION:-P1 - IHOLE
 ALL DIMENSION ARE IN M.M.
 UNSPECIFIED CORNER RADIUS:0.40

TOL. AS PER B.S.1474:1987
 UNLESS SPECIFIED

TWIST = ±1/4°/300 M.M./M.
 STRAIGHTNESS = 1.50 M.M./MTR.
 ANGULARITY = ±1.5°

INDO ALUSYS INDUSTRIES LIMITED BHIWADI RAJASTHAN - 301019

PARTY SAMPLE & DRG.		4290		PARTY NAME		M/S CARYAIRE		REF:-AS PER EMAIL ON Dt.-06.07.09	
				DRAWN	DHARMVIR	07.07.09	AREA	306.00	MM ²
	(C)	DIM. 2.80 WAS 3.055		CHECKED	<i>[Signature]</i>	20/8/09	WEIGHT	0.826	KG/M.
	(B)	DIM. 10.60 WAS 10.74		APPROVED	<i>[Signature]</i>	20/8/09	WT. RANGE	-----	Kg/12'
	(A)	DIM. 1.73 WAS 1.80		SCALE	1:1&3:1	DATE	ALLOY	6063-T5	
001	(REF.)	AS PER DRG. Dt.21.07.09		CRITICAL DIM. *			MAL NO	11265	
REV. STATUS	REV. NO.	DESCRIPTION	SIGN DATE	PERIMETER	INT.	-----	SEC.NO.	D-4785	
		REVISION			EXT.	346.80			