

MAL NO.-11438

D4845

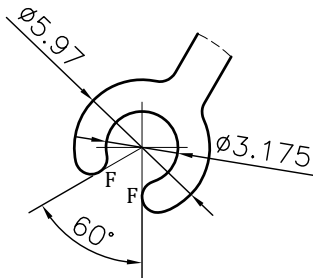
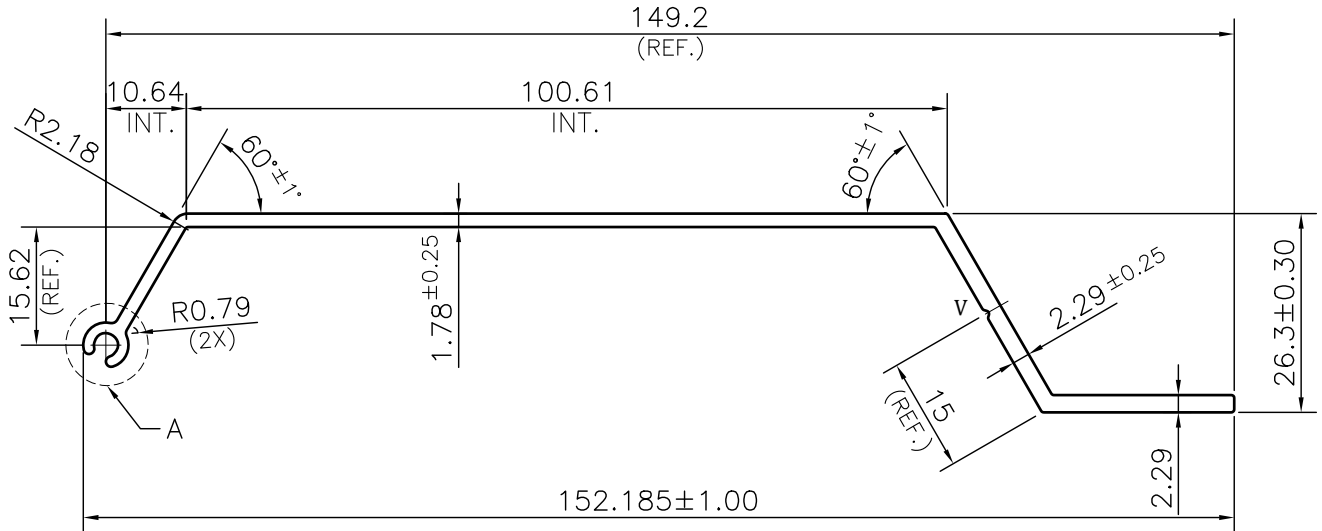

DETAIL A
SCALE 3:1

NOTE:-

F= FULL RADIUS (2 PLACES)
V= 0.5x90° V-GROOVE (1 PLACE)

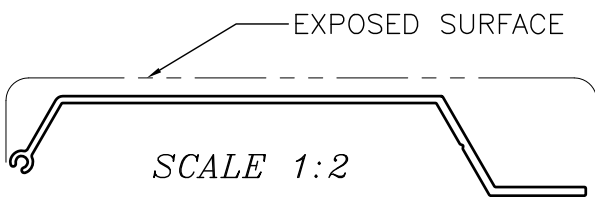

1. STRAIGHTNESS= 1.7mm/M
2. TWIST= 1.7mm/M
3. ANGULARITY= ±2°
4. FLATNESS= 0.007xWIDTH



SYMBOL OF QUALITY
AN ISO 9001 COMPANY

JINDAL ALUMINIUM LTD.
BHIWADI-301019 (INDIA)

	NAME	DATE
DRAWN	ASHUTOSH	27-03-2024
CHECKED		
APPROVED		
SCALE		1:1
AREA mm ²		344.359
PERIMETER mm.		364.52
WEIGHT kg/m		0.930
DRAWING No.	SECTION No.	
MAL NO.-11438	-	
D4845	D4845	

1. ALL DIMENSIONS ARE IN mm.
2. ROUND OFF ALL SHARP CORNERS WITH 0.40 mm.
3. TOLERANCES WILL BE AS PER BS:EN-755-9 , UNLESS OTHERWISE SPECIFIED

PARTY'S NAME	CARYAIRE	
PARTY'S DRAWING No.	AS PER DRAWING-70-010119-00B	
ALLOY & TEMPER	6063 T5	PRODUCT CODE:-082
		HSN CODE:- 76042990
DESCRIPTION	AIR GRILL SECTION	