

NOTE:-

- *= 1.00R
- O= 3.00R
- R=3.50R
- V= 0.50X1.00X90°

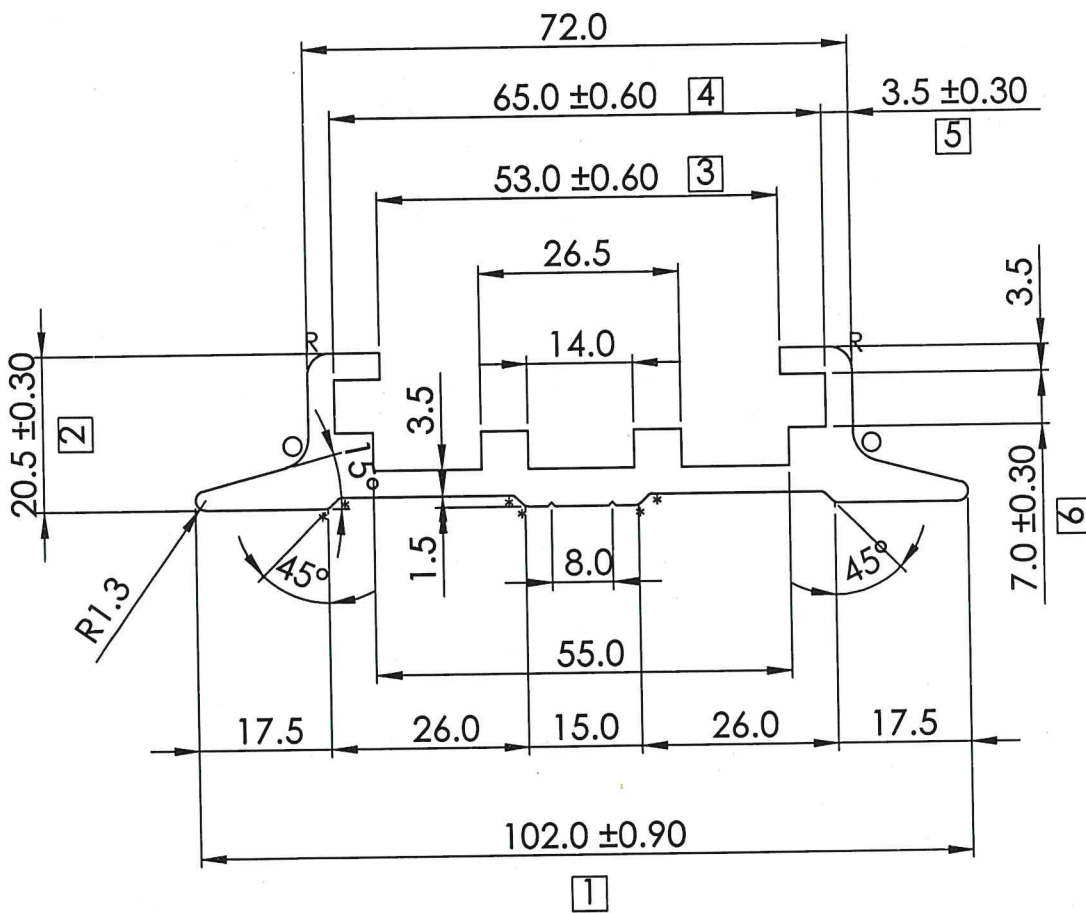
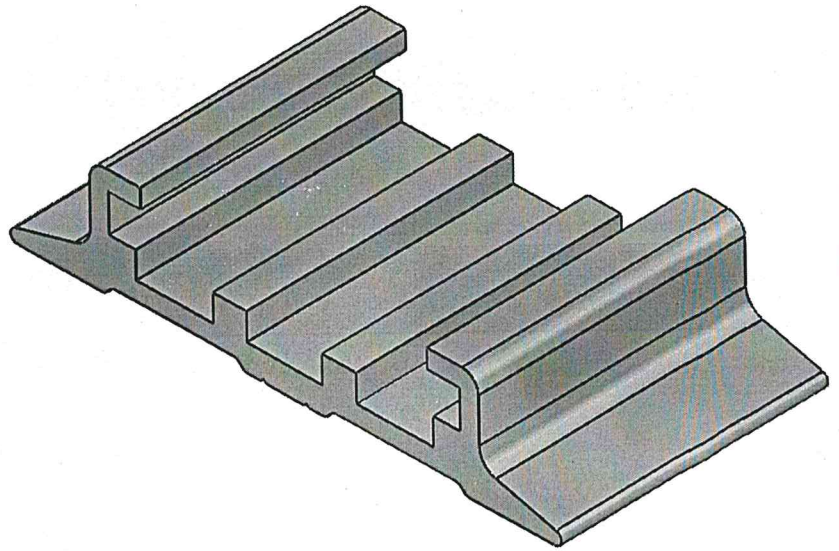

LOCATION:-P1 - 1HOLE
 ALL DIMENSION ARE IN M.M.
 UNSPECIFIED CORNER RADIUS:0.40

TOL. AS PER BS EN 755-9:2008
 UNLESS SPECIFIED

TWIST $\square = \pm 1/4^\circ / 300 \text{ M.M. / M.}$
 STRAIGHTNESS $\square = 1.50 \text{ M.M. / MTR.}$
 ANGULARITY $\square = \pm 1.5^\circ$

INDO ALUSYS INDUSTRIES LIMITED BHIWADI RAJASTHAN - 301019

PARTY SAMPLE & DRG.		DRG.	PARTY NAME M/S SMW			REF:- AS PER DRG. Dt.-27.07.10		
			DRAWN	DHARMVIR	28.07.10	AREA	676.00	MM ²
			CHECKED	<i>[Signature]</i>	01.9.10	WEIGHT	1.833	KG/M.
			APPROVED	<i>[Signature]</i>	01.9.10	WT. RANGE	-----	Kg/12'
			SCALE	1:1 & 2:1	DATE	ALLOY	6063-T6	
OO	(REF.)		CRITICAL DIM. *			MAL NO	11838	
REV. STATUS	REV. NO.	DESCRIPTION	SIGN DATE	PERIMETER	INT.	SEC.NO.	D-5022	
		REVISION		EXT.	309.81			