

MAL NO.-12085

D5129

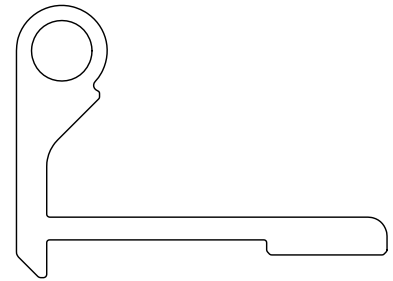

SCALE 1:1

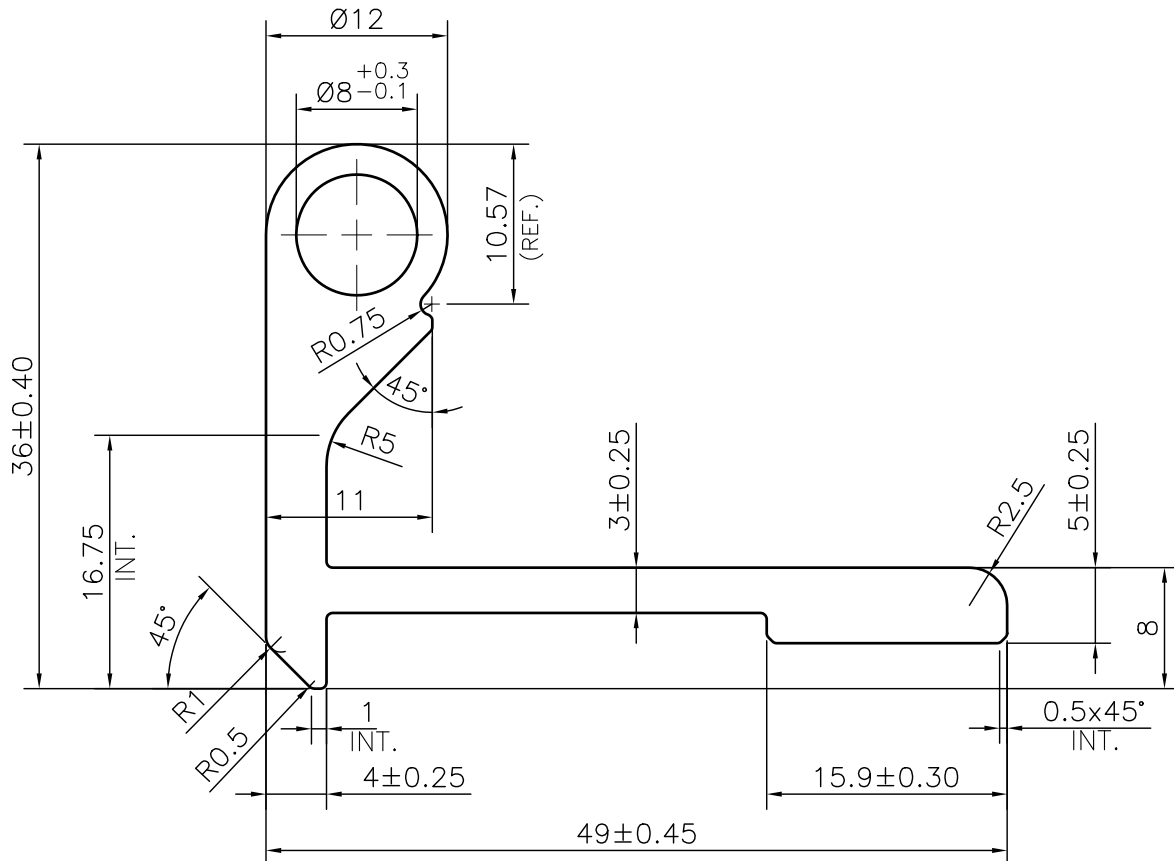

1. STRAIGHTNESS= 1.7mm/M
2. TWIST= 1.7mm/M
3. ANGULARITY= $\pm 2^\circ$
4. FLATNESS= 0.007xWIDTH



SYMBOL OF QUALITY
AN ISO 9001 COMPANY

JINDAL ALUMINIUM LTD.
BHIWADI-301019 (INDIA)

	NAME	DATE
DRAWN	ASHUTOSH	17-02-2024
CHECKED		
APPROVED		
SCALE		2:1
AREA mm ²		356.997
PERIMETER mm.		176.073
WEIGHT kg/m		0.964
DRAWING No.		SECTION No.
MAL NO.-12085		-
D5129		D5129

1. ALL DIMENSIONS ARE IN mm.
2. ROUND OFF ALL SHARP CORNERS WITH 0.40 mm.
3. TOLERANCES WILL BE AS PER BS:EN-755-9 , UNLESS OTHERWISE SPECIFIED

PARTY'S NAME	AJAY INDUSTRIAL	
PARTY'S DRAWING No.	AS PER DRAWING- ALUM001	
ALLOY & TEMPER	6060 T6	PRODUCT CODE:-034
		HSN CODE:- 76042100
DESCRIPTION	SPECIAL HINGES SECTION	