

IAL-D-521

D521

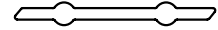

SCALE 1:1

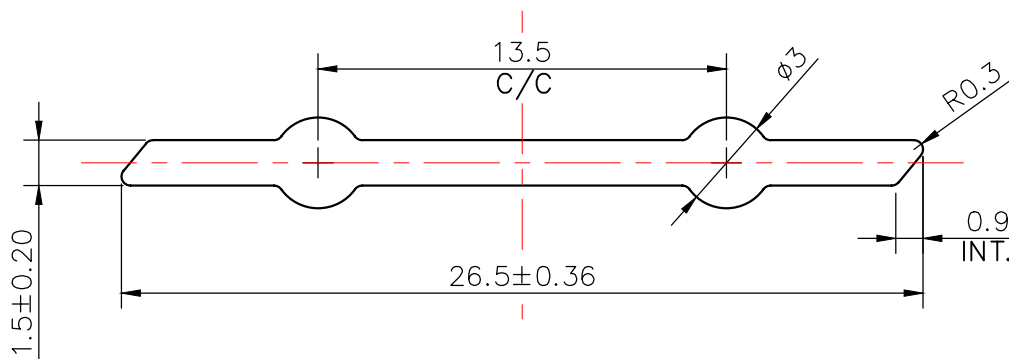

1. STRAIGHTNESS= 1.7mm/M
2. TWIST= 1.7mm/M
3. ANGULARITY= $\pm 2^\circ$
4. FLATNESS= 0.007xWIDTH



SYMBOL OF QUALITY
AN ISO 9001 COMPANY

JINDAL ALUMINIUM LTD.
BHIWADI-301019 (INDIA)

	NAME	DATE
DRAWN	ASHUTOSH	25-07-2023

CHECKED		
APPROVED		

SCALE	4:1
-------	-----

AREA mm ²	44.28
----------------------	-------

PERIMETER mm.	56.49
---------------	-------

WEIGHT kg/m	0.121
-------------	-------

DRAWING No.	SECTION No.
IAL-D-521	
D521	D521

--	--

--	--

--	--

1. ALL DIMENSIONS ARE IN mm.
2. ROUND OFF ALL SHARP CORNERS WITH 0.40 mm.
3. TOLERANCES WILL BE AS PER BS:EN-755-9 , UNLESS OTHERWISE SPECIFIED

PARTY'S NAME	CARYAIRE
PARTY'S DRAWING No.	AS PER DRAWING
ALLOY & TEMPER	HE9 WP
DESCRIPTION	AIR GRILL SECTION