

MAL-12664

D5353

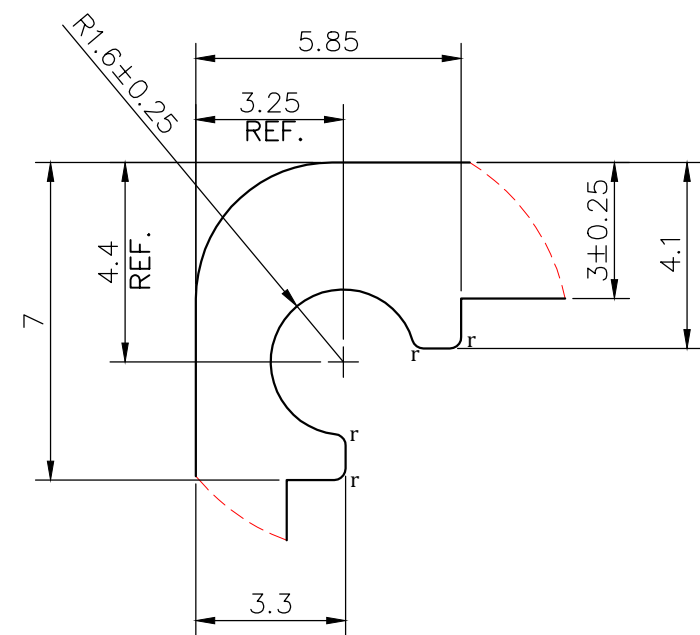

DETAIL-A
SCALE 6:1

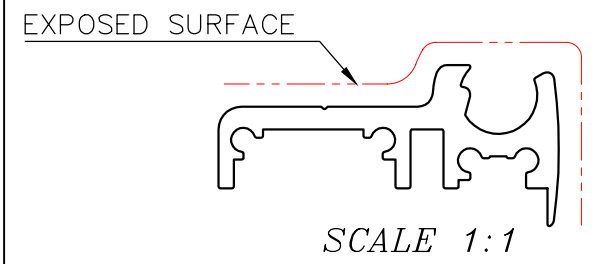
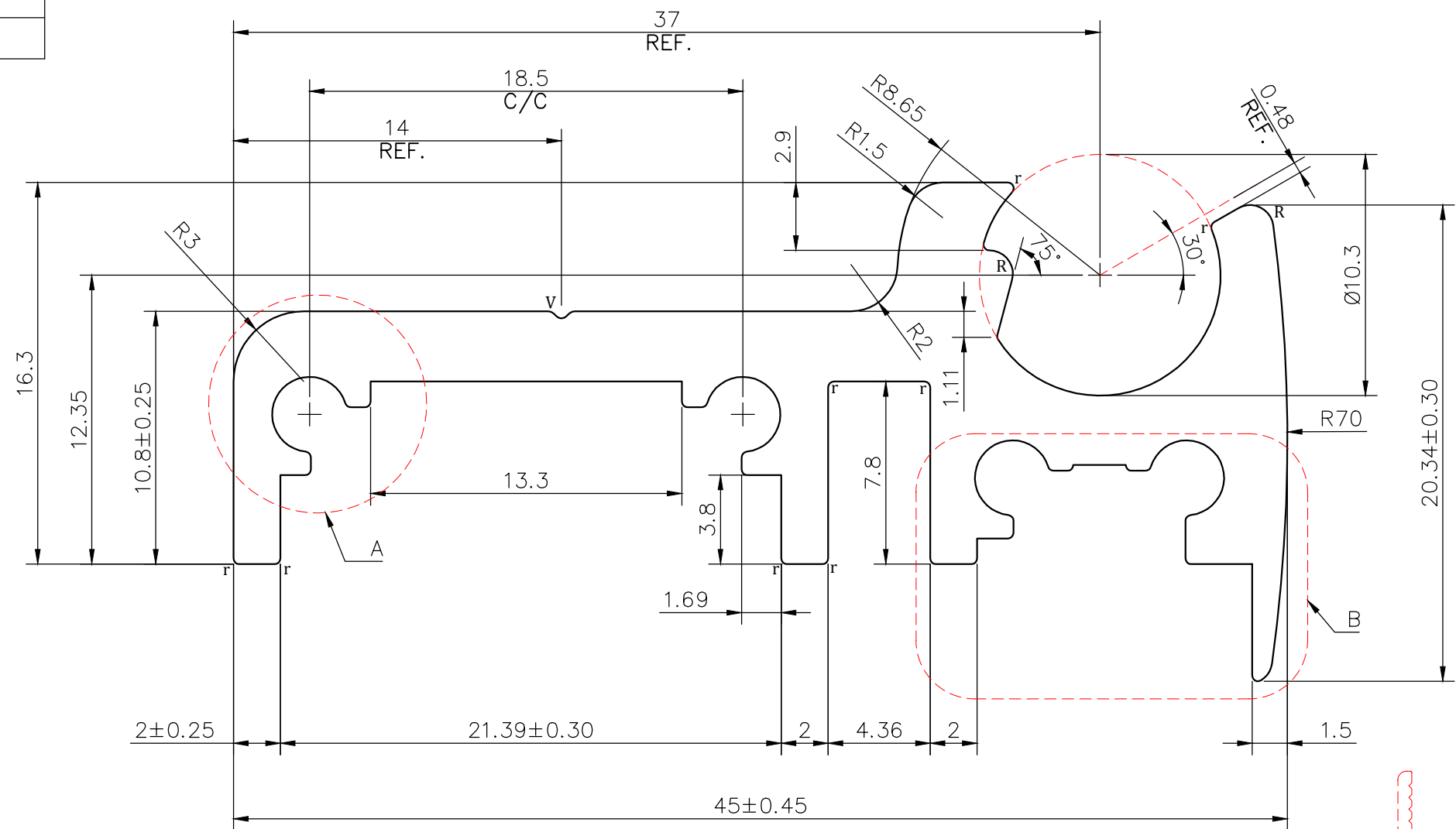
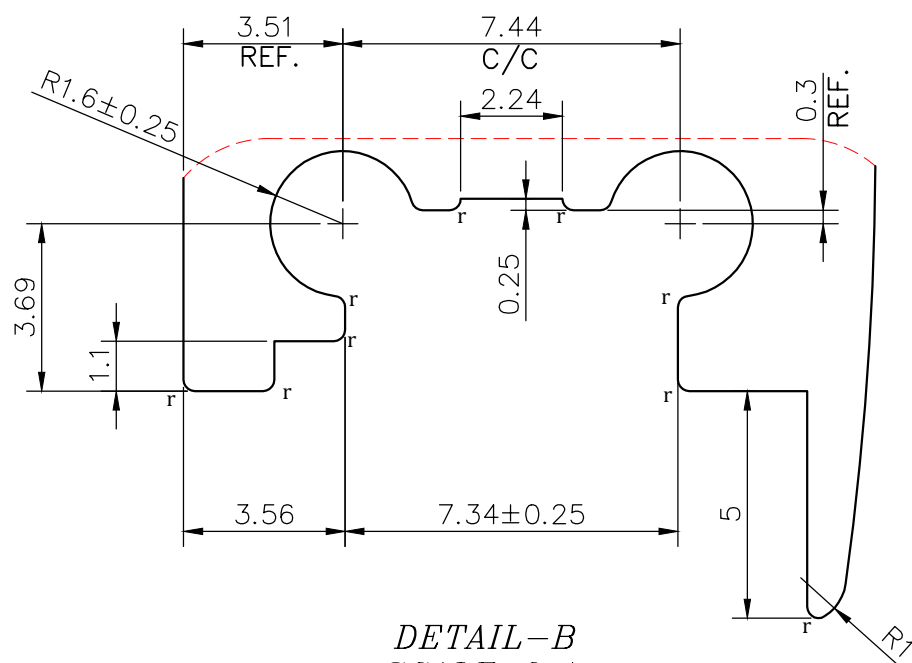

DETAIL-B
SCALE 6:1

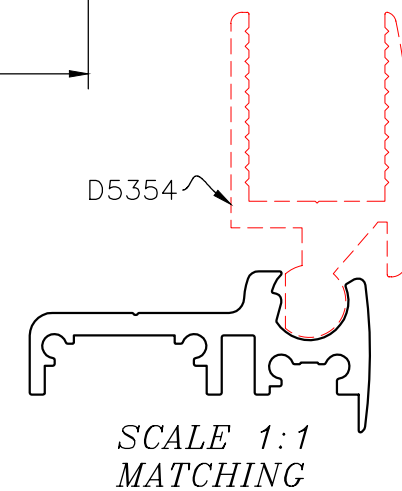

NOTE:-
r= 0.25 RADIUS
R= 1.0 RADIUS
V= 0.3x90° V-GROOVE

1. STRAIGHTNESS= 1.7mm/M
2. TWIST= 1.7mm/M
3. ANGULARITY= ±2°
4. FLATNESS= 0.007xWIDTH

 SYMBOL OF QUALITY AN ISO 9001 COMPANY	JINDAL ALUMINIUM LTD. BHIWADI-301019 (INDIA)	NAME	DATE
		DRAWN	ASHUTOSH 14-07-2023
1. ALL DIMENSIONS ARE IN mm. 2. ROUND OFF ALL SHARP CORNERS WITH 0.40 mm. 3. TOLERANCES WILL BE AS PER BS:EN-755-9, UNLESS OTHERWISE SPECIFIED		CHECKED	
PARTY'S NAME		APPROVED	
ANTARCTICA EQUIPMENT		SCALE	4:1
PARTY'S DRAWING No.		AREA mm ²	260.16
ALLOY & TEMPER		PERIMETER mm.	194.76
6060		WEIGHT kg/m	0.702
DESCRIPTION		DRAWING No.	SECTION No.
REFRIGERATOR SECTION		MAL-12664	
		D5353	D5353