

MAL-12846

D5420

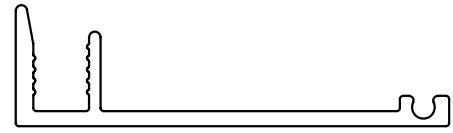

SCALE 1:1

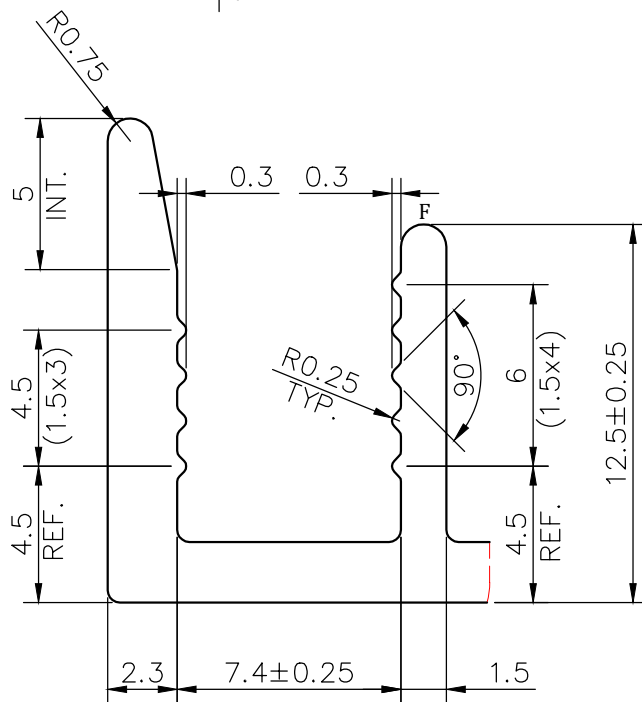
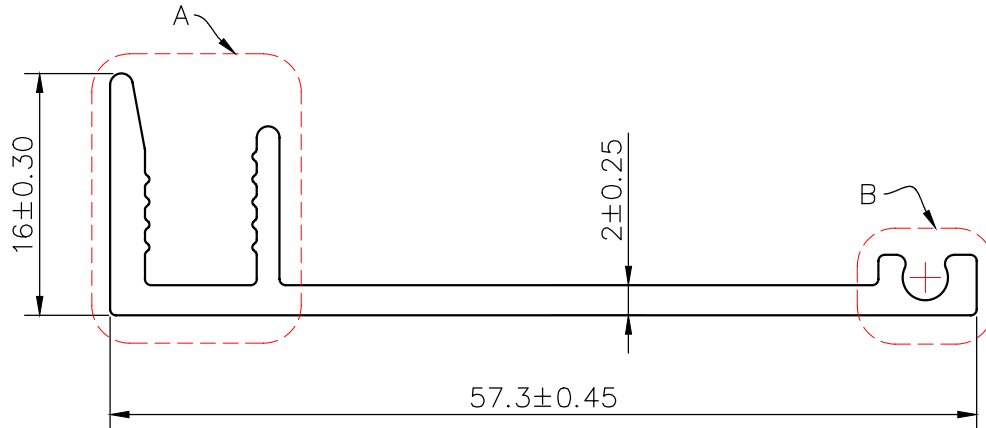

DETAIL A
SCALE 4:1

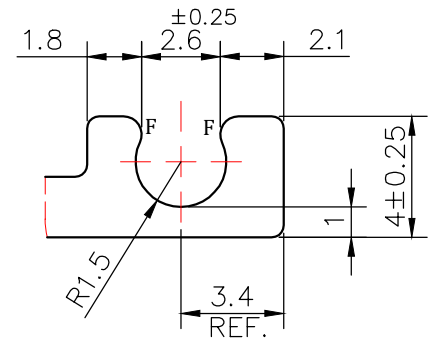

DETAIL B
SCALE 4:1

NOTE:-**F= FULL RADIUS (3 PLACES)**

1. STRAIGHTNESS= 1.7mm/M
2. TWIST= 1.7mm/M
3. ANGULARITY= $\pm 2^\circ$
4. FLATNESS= 0.007xWIDTH



SYMBOL OF QUALITY
AN ISO 9001 COMPANY

JINDAL ALUMINIUM LTD.
BHIWADI-301019 (INDIA)

	NAME	DATE
DRAWN	ASHUTOSH	17-08-2023
CHECKED		
APPROVED		
SCALE		2:1
AREA mm ²		166.367
PERIMETER mm.		174.71
WEIGHT kg/m		0.449
DRAWING No.		SECTION No.
MAL-12846		
D5420		D5420

1. ALL DIMENSIONS ARE IN mm.
2. ROUND OFF ALL SHARP CORNERS WITH 0.40 mm.
3. TOLERANCES WILL BE AS PER BS:EN-755-9, UNLESS OTHERWISE SPECIFIED

PARTY'S NAME	3R CONSTRUCTION SOLUTION	
PARTY'S DRAWING No.	AS PER DRAWING	
ALLOY & TEMPER	6063 T6	PRODUCT CODE: -051 HSN CODE: -76042990
DESCRIPTION	MODULAR SECTION	