

MAL NO.-12785

D5487

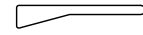

SCALE 1:1

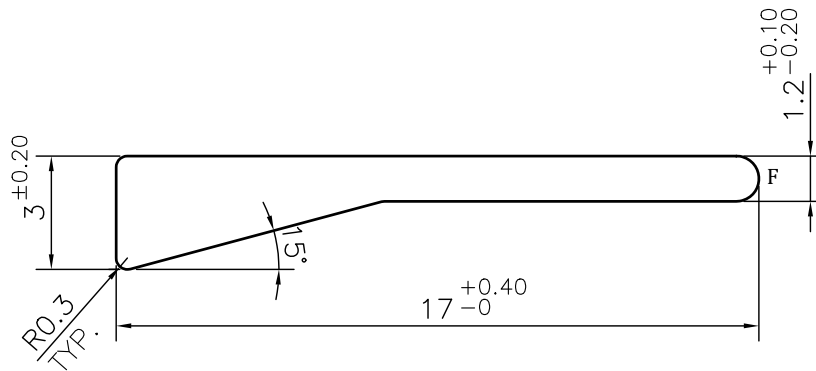

NOTE:-

F= FULL RADIUS (1 PLACE)

- 1. STRAIGHTNESS= 1.7mm/M
- 2. TWIST= 1.7mm/M
- 3. ANGULARITY= ±2°
- 4. FLATNESS= 0.007xWIDTH



SYMBOL OF QUALITY
AN ISO 9001 COMPANY

JINDAL ALUMINIUM LTD.
BHIWADI-301019 (INDIA)

	NAME	DATE
DRAWN	ASHUTOSH	21-08-2024
CHECKED		
APPROVED		
SCALE		5:1
AREA mm ²		26.864
PERIMETER mm.		37.66
WEIGHT kg/m		0.073
DRAWING No.		SECTION No.
MAL NO.-12785		-
D5487		D5487

- 1. ALL DIMENSIONS ARE IN mm.
- 2. ROUND OFF ALL SHARP CORNERS WITH 0.40 mm.
- 3. TOLERANCES WILL BE AS PER BS:EN-755-9 , UNLESS OTHERWISE SPECIFIED

PARTY'S NAME	RAVISTAR INDIA PVT. LTD.	
PARTY'S DRAWING No.	AS PER DRAWING-Y-SR0007-5	
ALLOY & TEMPER	6060 T5	PRODUCT CODE:-082
		HSN CODE:- 76042990
DESCRIPTION	AIR GRILL SECTION	