

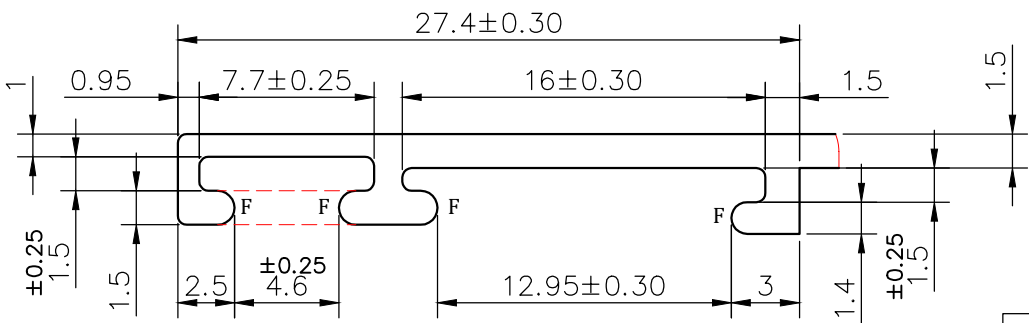

MAL-12945
D5595

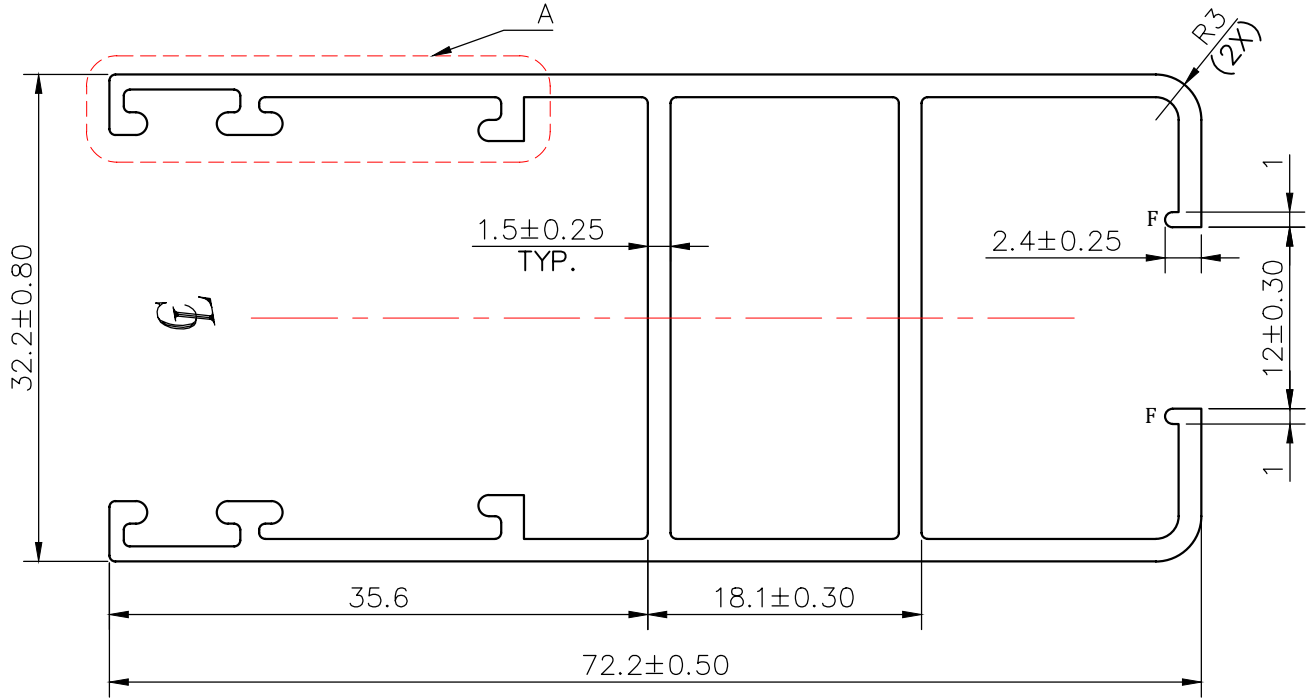
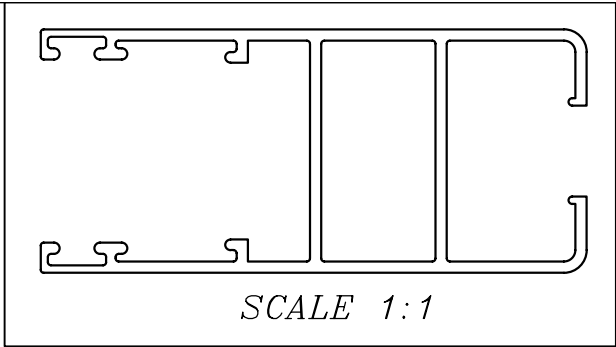

DETAIL-A
SCALE 3:1

1. STRAIGHTNESS= 1.7mm/M
2. TWIST= 1.7mm/M
3. ANGULARITY= ±2°
4. FLATNESS= 0.007xWIDTH

 SYMBOL OF QUALITY AN ISO 9001 COMPANY	JINDAL ALUMINIUM LTD. BHIWADI-301019 (INDIA)	NAME	DATE
		DRAWN	ASHUTOSH 14-07-2023
		CHECKED	
		APPROVED	
1. ALL DIMENSIONS ARE IN mm. 2. ROUND OFF ALL SHARP CORNERS WITH 0.40 mm. 3. TOLERANCES WILL BE AS PER BS:EN-755-9 , UNLESS OTHERWISE SPECIFIED		SCALE	1:1
		AREA mm ²	357.66
		PERIMETER mm.	399.73
		WEIGHT kg/m	0.966
		DRAWING No.	SECTION No.
		MAL-12945	
		D5595	D5595
PARTY'S NAME	AGV ALFAB		
PARTY'S DRAWING No.	AS PER DRAWING		
ALLOY & TEMPER	6063 T6		
DESCRIPTION	WINDOW SECTION		