

MAL NO.-13027

D5601

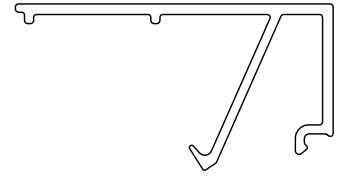

SCALE 1:1

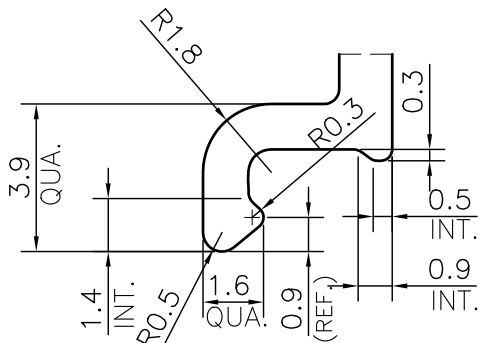
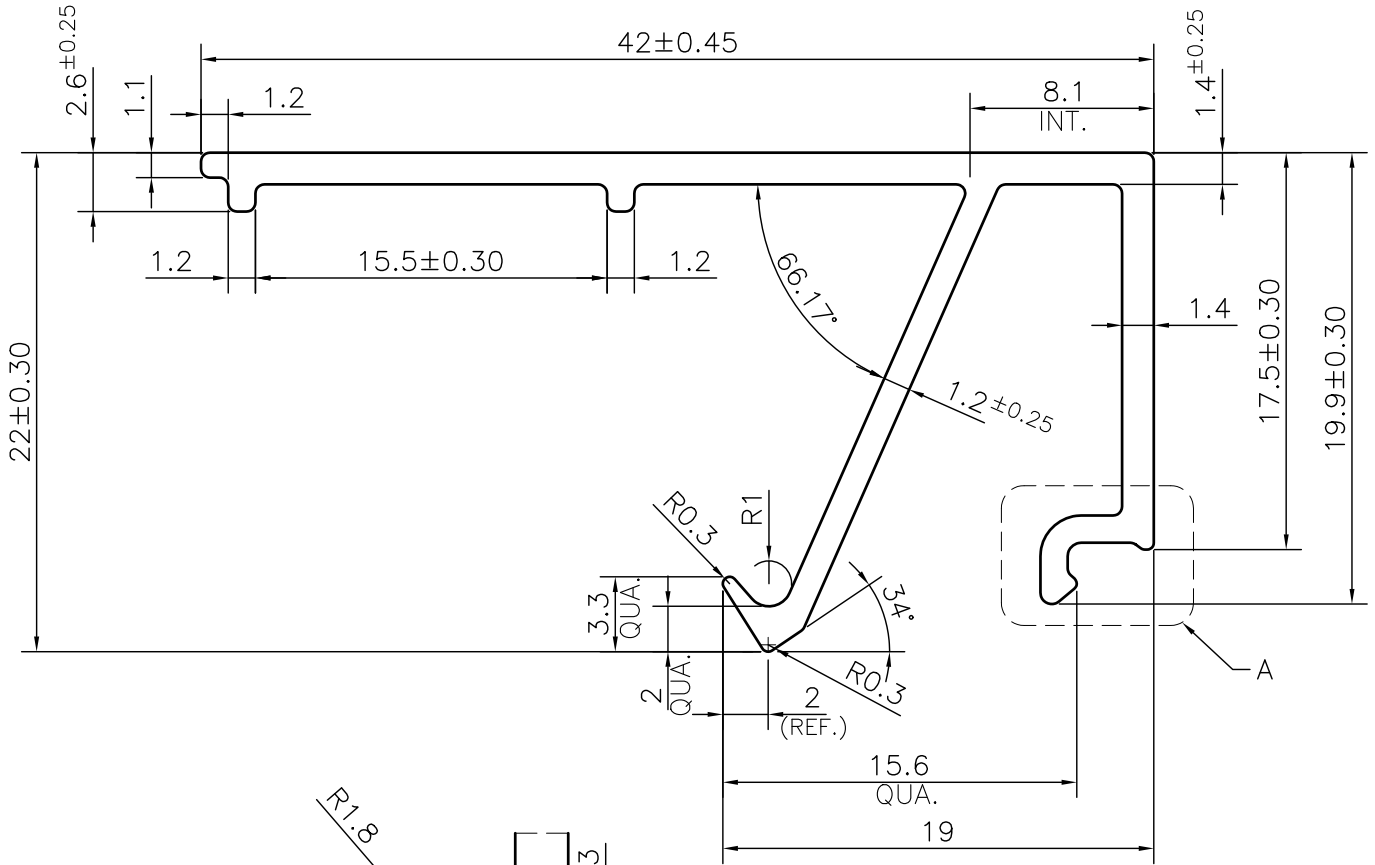

DETAIL A
SCALE 5:1

- 1. STRAIGHTNESS= 1.7mm/M
- 2. TWIST= 1.7mm/M
- 3. ANGULARITY= ±2°
- 4. FLATNESS= 0.007xWIDTH



SYMBOL OF QUALITY
AN ISO 9001 COMPANY

JINDAL ALUMINIUM LTD.
BHIWADI-301019 (INDIA)

	NAME	DATE
DRAWN	ASHUTOSH	22-12-2023
CHECKED		
APPROVED		
SCALE		3:1
AREA mm ²		120.437
PERIMETER mm.		181.3
WEIGHT kg/m		0.325
DRAWING No.	SECTION No.	
MAL NO.-13027	-	
D5601	D5601	

- 1. ALL DIMENSIONS ARE IN mm.
- 2. ROUND OFF ALL SHARP CORNERS WITH 0.40 mm.
- 3. TOLERANCES WILL BE AS PER BS:EN-755-9 , UNLESS OTHERWISE SPECIFIED

PARTY'S NAME	AAP DIVISON	
PARTY'S DRAWING No.	AS PER DRAWING-JF3	
ALLOY & TEMPER	6063 T6	PRODUCT CODE:-044
		HSN CODE:- 76042990
DESCRIPTION	GLAZING CLIP SECTION	