

MAL NO.-13030

D5604

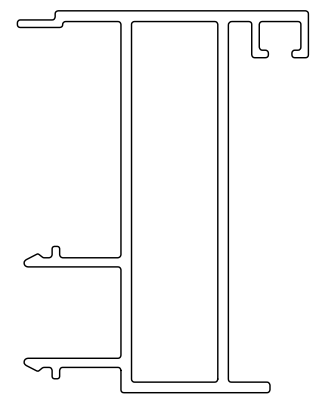

SCALE 1:1

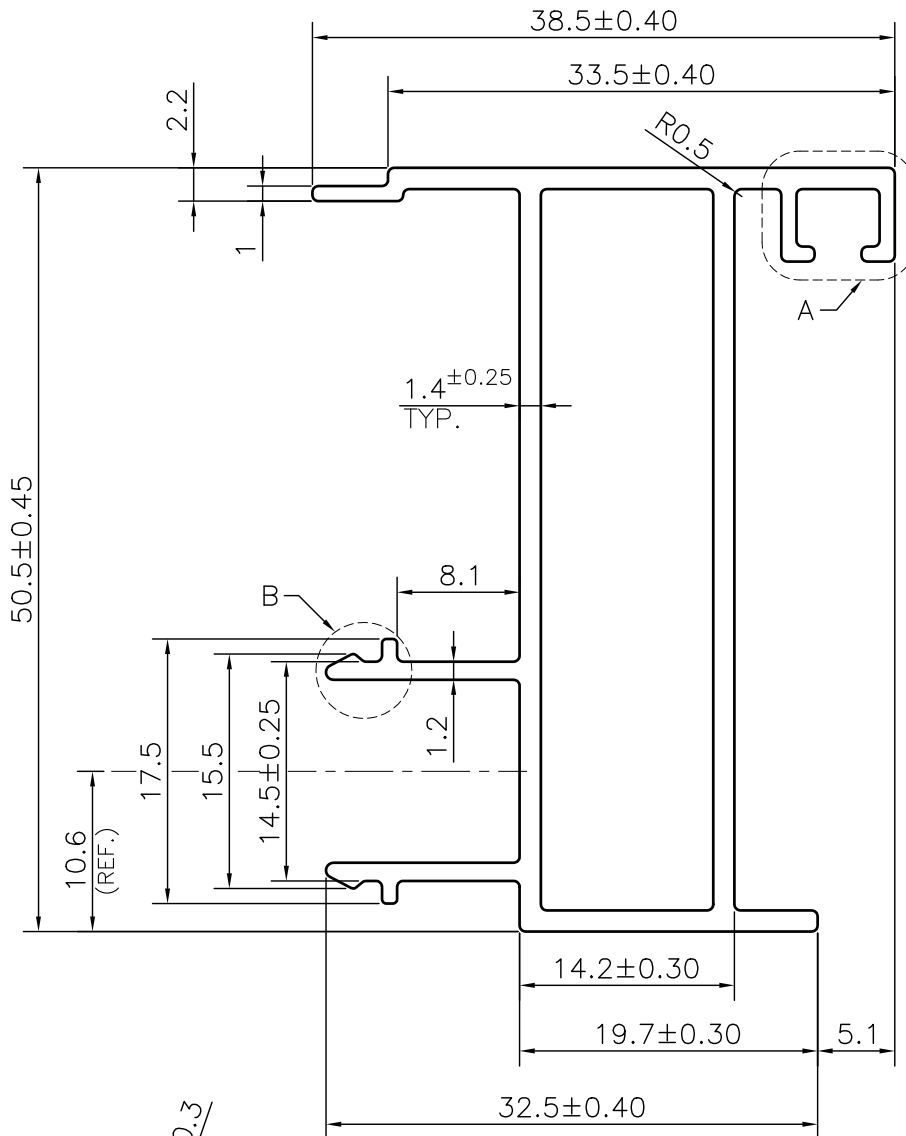
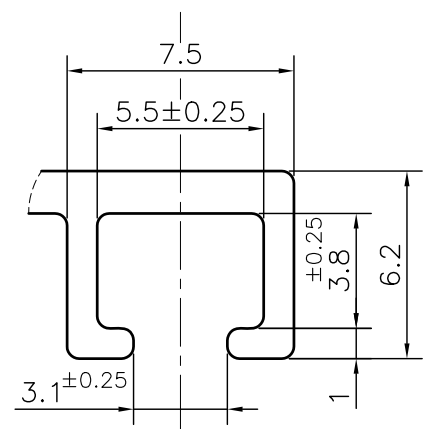

DETAIL A
SCALE 4:1

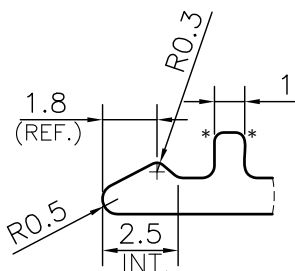

DETAIL B
SCALE 4:1

NOTE:-

***= 0.30 RADIUS (4 PLACES)**

1. STRAIGHTNESS= 1.7mm/M
2. TWIST= 1.7mm/M
3. ANGULARITY= ±2°
4. FLATNESS= 0.007xWIDTH



SYMBOL OF QUALITY
AN ISO 9001 COMPANY

JINDAL ALUMINIUM LTD.
BHIWADI-301019 (INDIA)

| | NAME | DATE |
|----------------------|-------------|------------|
| DRAWN | ASHUTOSH | 22-12-2023 |
| CHECKED | | |
| APPROVED | | |
| SCALE | | 2:1 |
| AREA mm ² | | 260.297 |
| PERIMETER mm. | | 265.159 |
| WEIGHT kg/m | | 0.703 |
| DRAWING No. | SECTION No. | |
| MAL NO.-13030 | - | |
| D5604 | D5604 | |

1. ALL DIMENSIONS ARE IN mm.
2. ROUND OFF ALL SHARP CORNERS WITH 0.40 mm.
3. TOLERANCES WILL BE AS PER BS:EN-755-9 , UNLESS OTHERWISE SPECIFIED

| | | |
|---------------------|--------------------|---------------------|
| PARTY'S NAME | AAP DIVISION | |
| PARTY'S DRAWING No. | AS PER DRAWING-JD4 | |
| ALLOY & TEMPER | 6063 T6 | PRODUCT CODE:-048 |
| | | HSN CODE:- 76042100 |
| DESCRIPTION | WINDOW SECTION | |