

DETAIL B  
SCALE 5 : 1

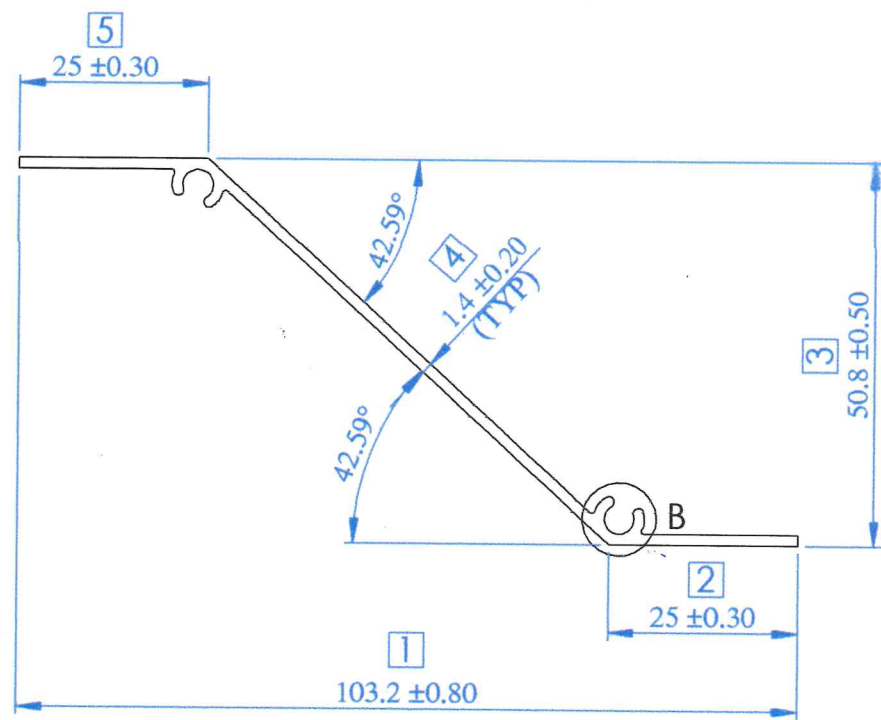

NOTE:-  
F= Full Radius

LOCATION:-P3 - 1HOLE  
ALL DIMENSION ARE IN mm.  
UNSPECIFIED CORNER RADIUS:0.40

**PLEASE SPECIFY THE EXPOSED SURFACE**

TOL. AS PER IS :3965-1981  
UNLESS SPECIFIED

TWIST=±1/4°/300 M.M./M.  
FLATNESS= WIDTH X 0.005mm.  
STRAIGHTNESS= 1.50 M.M./MTR.  
ANGULARITY=±1.5°

**INDO ALUSYS INDUSTRIES LIMITED BHIWADI RAJASTHAN - 301019**

PARTY SAMPLE & DRG.		21150		PARTY NAME M/S GLAZE TECNO INDIA			REF:- AS PER EMAIL ON Dt.-08.01.12		
				DRAWN	DHARMVIR	12.01.13	AREA	192.30	MM <sup>2</sup>
				CHECKED	<i>[Signature]</i>	12-2-13	WEIGHT	0.519	KG/M.
				APPROVED	<i>[Signature]</i>	12-2-13	WT. RANGE	-----	Kg/12
				SCALE	1:1 & 5:1	DATE	ALLOY	HE9 WP	
00	(REF.)			CRITICAL DIM.	*		MAL NO	13445	
REV. STATUS	REV. NO.	DESCRIPTION	SIGN DATE	PERIMETER	INT.		SEC.NO.	D-5721	
		REVISION			EXT.	270.36			