

ADDONE

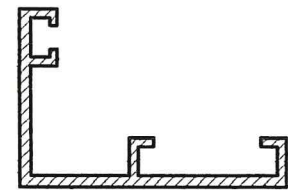

ACTUAL SIZE

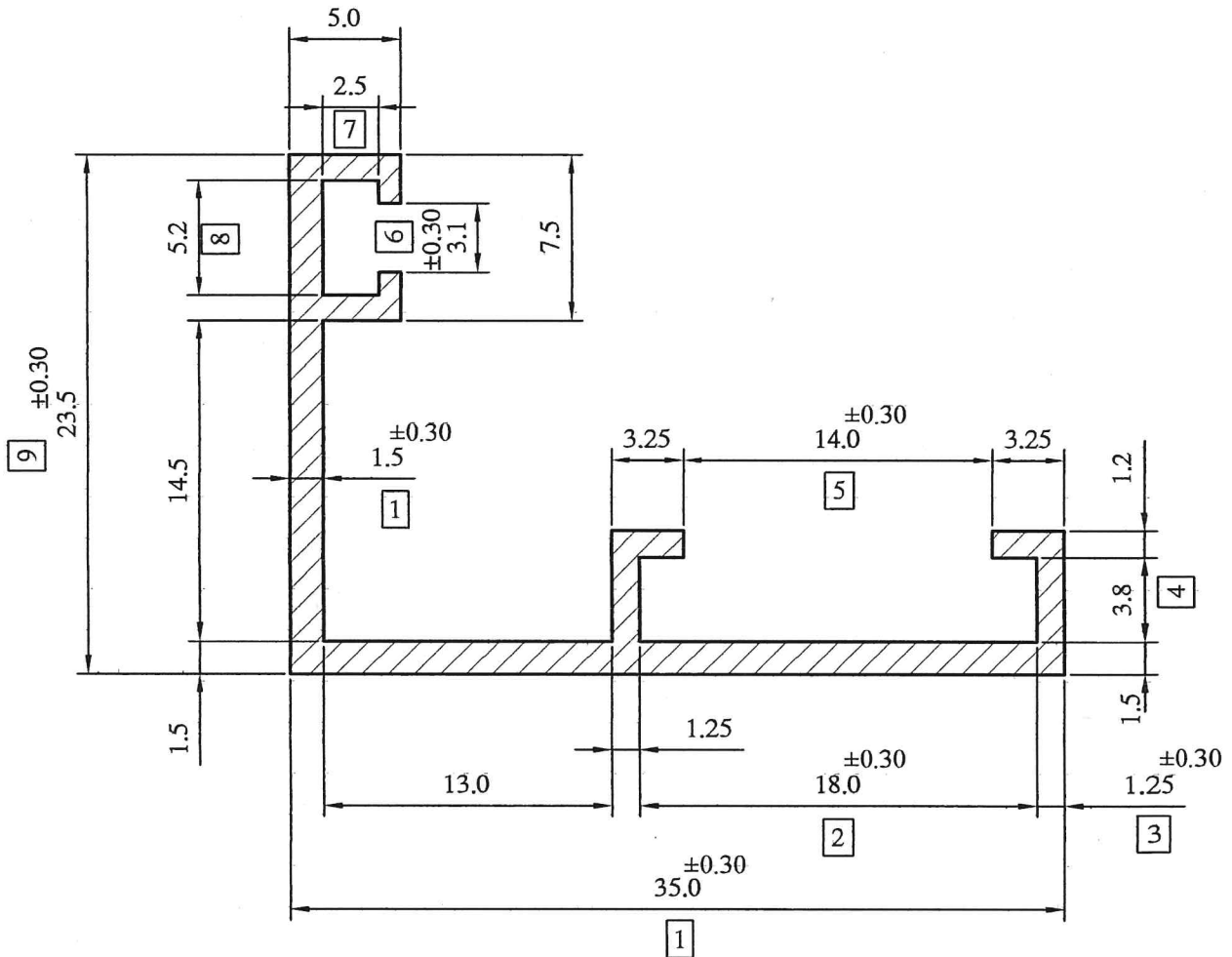

ADDON

PLEASE SPECIFY THE EXPOSED SURFACE

LOCATION:-P2 - 2HOLE
 ALL DIMENSION ARE IN M.M.
 UNSPECIFIED CORNER RADIUS:0.40

TOL. AS PER IS : 3965-1981
 UNLESS SPECIFIED

TWIST = ±1/4°/300 mm./mtr.
 FLATNESS = WIDTH X 0.005mm.
 STRAIGHTNESS = 1.50 mm./mtr.
 ANGULARITY = ±1.5°

INDO ALUSYS INDUSTRIES LIMITED BHIWADI RAJASTHAN - 301019

PARTY SAMPLE & DRG.		DRG.	PARTY NAME J.P. ASSOCIATES			REF:-AS PER EMAIL ON Dt.-16.01.13		
			DRAWN	DHARMVIR	19.01.13	AREA	112.11	MM ²
			CHECKED	<i>SP</i>	4.3.13	WEIGHT	0.302	KG/M.
			APPROVED	<i>SP</i>	4.3.13	WT. RANGE	-----	Kg/12'
			SCALE	1:1 & 3:1	DATE	ALLOY	HE9 WP	
00	(REF.)		CRITICAL DIM. *			MAL NO	13476	
REV. STATUS	REV. NO.	DESCRIPTION	SIGN DATE	PERIMETER	INT.	-----	SEC.NO.	D-5754
		REVISION			EXT.	163.00		