

MAL NO-13978

D5990

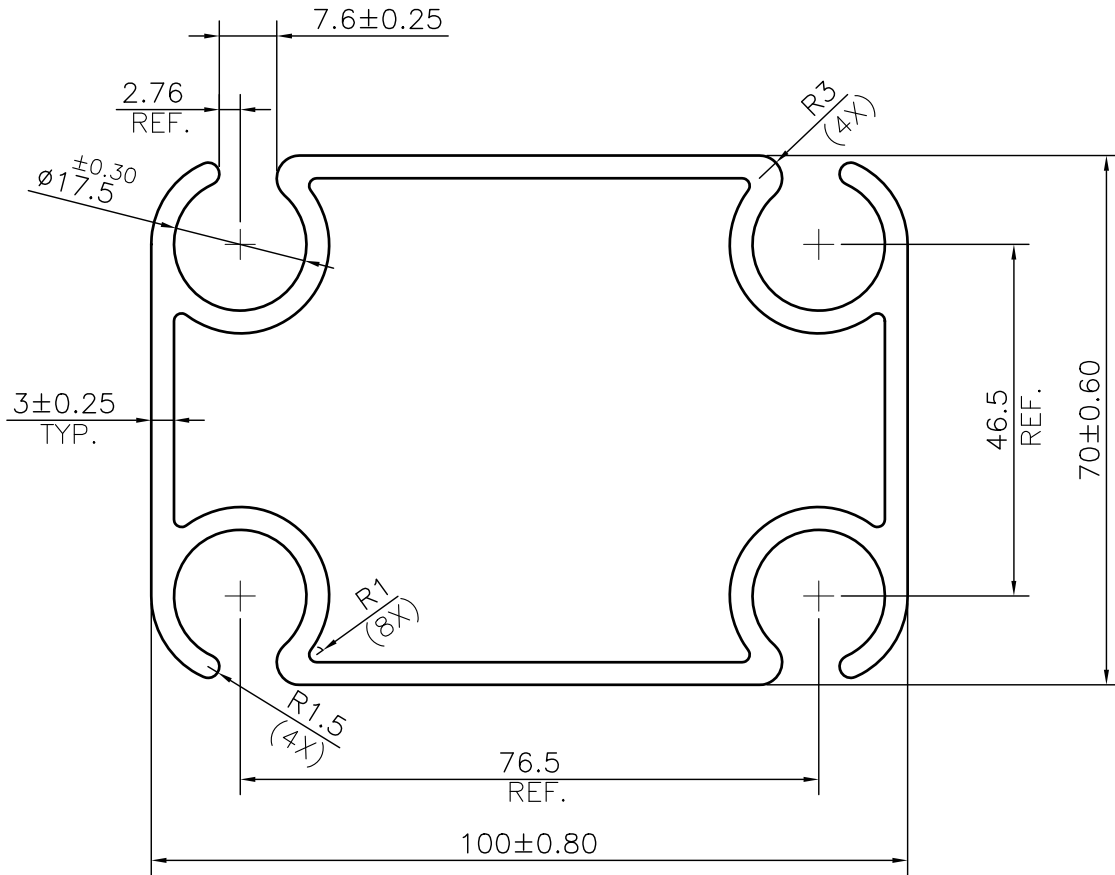

1. STRAIGHTNESS= 1.7mm/M
2. TWIST= 1.7mm/M
3. ANGULARITY= $\pm 2^\circ$
4. FLATNESS= 0.007xWIDTH



SYMBOL OF QUALITY
AN ISO 9001 COMPANY

JINDAL ALUMINIUM LTD.
BHIWADI-301019 (INDIA)

	NAME	DATE
DRAWN	ASHUTOSH	05-10-2023
CHECKED		
APPROVED		
SCALE		1:1
AREA mm ²		1275.508
PERIMETER mm.		495.447
WEIGHT kg/m		3.444
DRAWING No.		SECTION No.
MAL NO-13978		-
D5990		D5990

1. ALL DIMENSIONS ARE IN mm.
2. ROUND OFF ALL SHARP CORNERS WITH 0.40 mm.
3. TOLERANCES WILL BE AS PER BS:EN-755-9 , UNLESS OTHERWISE SPECIFIED

PARTY'S NAME	FAB INDIA	
PARTY'S DRAWING No.	AS PER DRAWING	
ALLOY & TEMPER	6063 T6	PRODUCT CODE:-047
		HSN CODE:- 76042100
DESCRIPTION	TENT HOUSE SECTION	