

MAL-14499

D6238

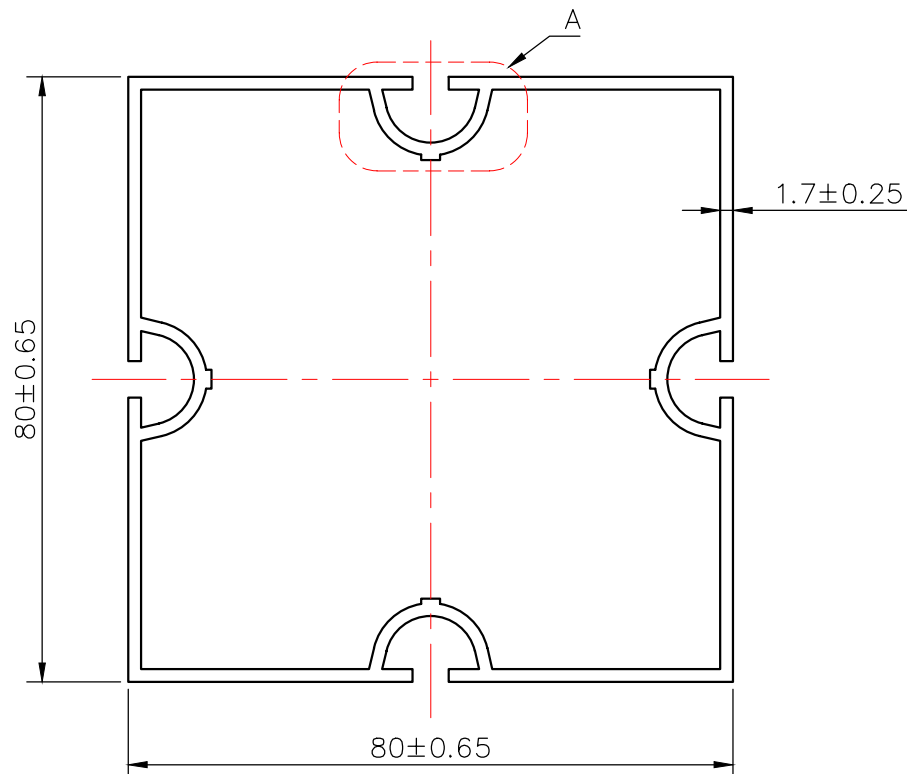

1. STRAIGHTNESS= 1.7mm/M
2. TWIST= 1.7mm/M
3. ANGULARITY= $\pm 2^\circ$
4. FLATNESS= 0.007xWIDTH

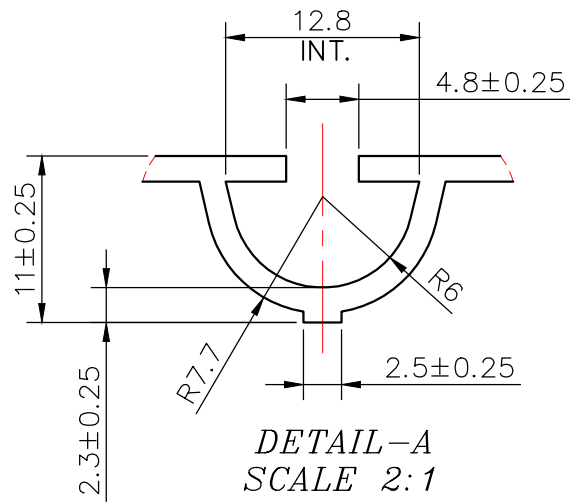

SYMBOL OF QUALITY
AN ISO 9001 COMPANY

JINDAL ALUMINIUM LTD.
BHIWADI-301019 (INDIA)

	NAME	DATE
DRAWN	ASHUTOSH	14-07-2023

CHECKED

APPROVED

SCALE

1:1

AREA mm²

666.84

PERIMETER mm.

430.22

WEIGHT kg/m

1.800

DRAWING No.

SECTION No.

MAL-14499

D6238

D6238

PARTY'S NAME

ATCO ALUMINIUM

PARTY'S DRAWING No.

AS PER DRAWING

ALLOY & TEMPER

HE9 WP

DESCRIPTION

DISPLAY SECTION