

MAL NO.-15132

D6501

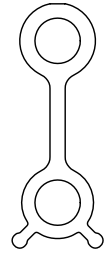

SCALE 1:1

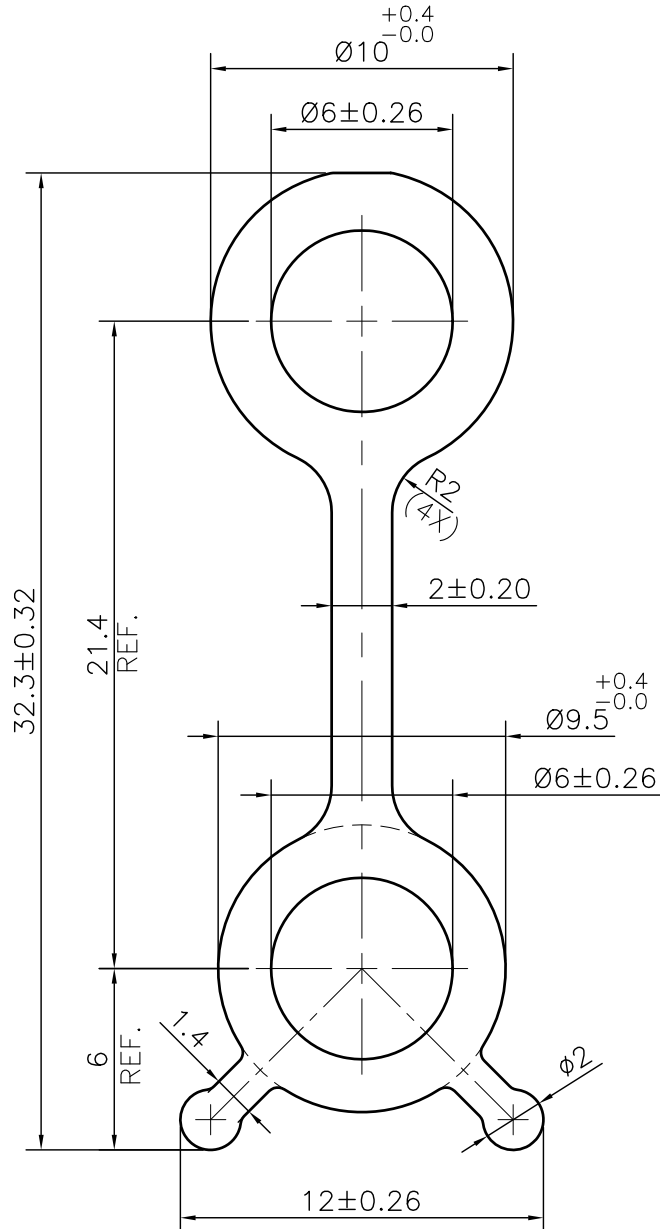

1. STRAIGHTNESS= 1.7mm/M
2. TWIST= 1.7mm/M
3. ANGULARITY= $\pm 2^\circ$
4. FLATNESS= 0.007xWIDTH



SYMBOL OF QUALITY
AN ISO 9001 COMPANY

JINDAL ALUMINIUM LTD.
BHIWADI-301019 (INDIA)

	NAME	DATE
DRAWN	ASHUTOSH	06-11-2023
CHECKED		
APPROVED		
SCALE		4:1
AREA mm ²		127.871
PERIMETER mm.		92.246
WEIGHT kg/m		0.345
DRAWING No.		SECTION No.
MAL NO.-15132		-
D6501		D6501

1. ALL DIMENSIONS ARE IN mm.
2. ROUND OFF ALL SHARP CORNERS WITH 0.40 mm.
3. TOLERANCES WILL BE AS PER BS:EN-755-9 , UNLESS OTHERWISE SPECIFIED

PARTY'S NAME SYSTEMAIR INDIA PVT. LTD.

PARTY'S DRAWING No. AS PER DRAWING

ALLOY & TEMPER 6063 T6 PRODUCT CODE:-082
HSN CODE:- 76042100

DESCRIPTION AIR GRILL SECTION