

MAL NO-15154

D6525

EXPOSED SURFACE

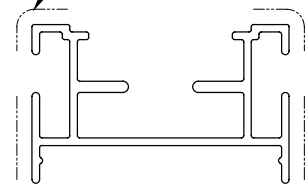

SCALE 1:1

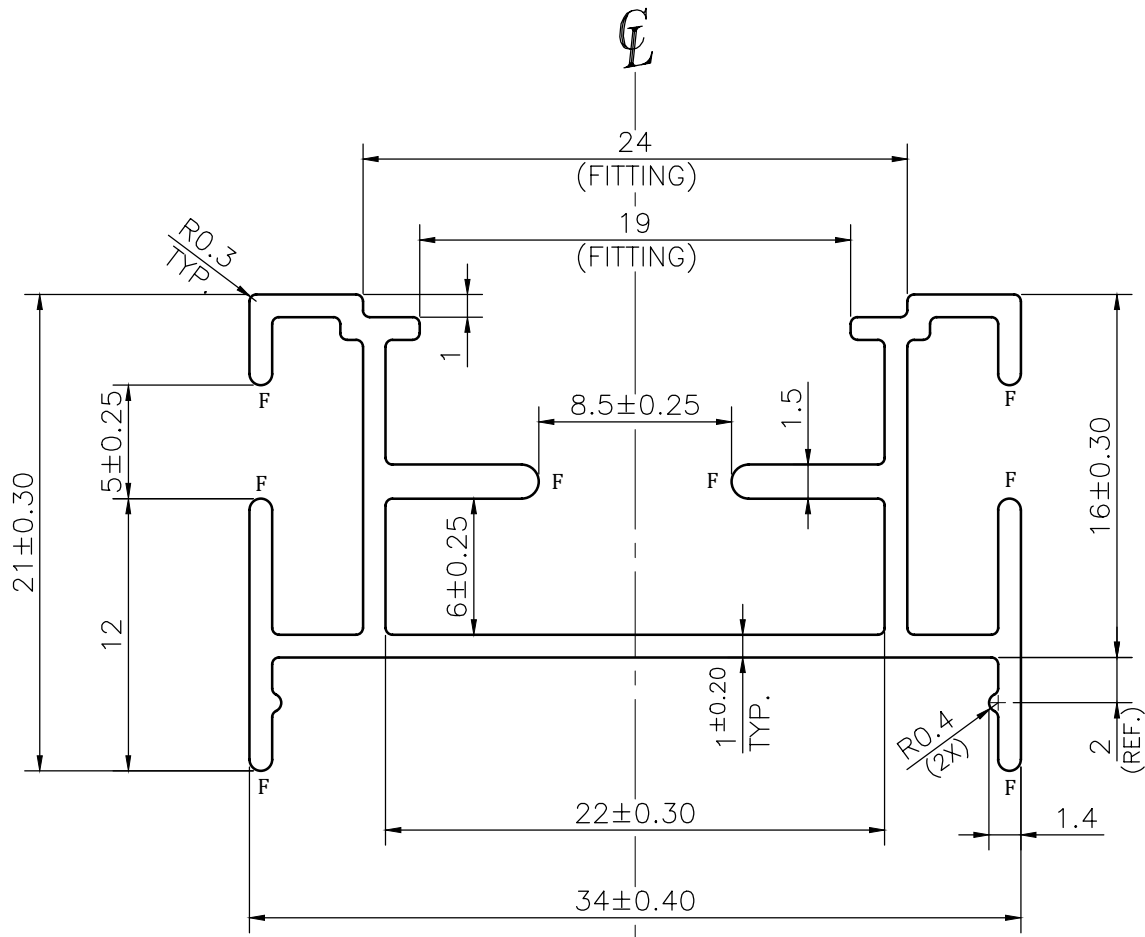
**NOTE:-****F= FULL RADIUS (8 PLACES)**

ROUND OFF ALL SHARP CORNERS WITH 0.30 mm.

1. STRAIGHTNESS= 1.7mm/M
2. TWIST= 1.7mm/M
3. ANGULARITY= $\pm 2^\circ$
4. FLATNESS= 0.007xWIDTH



SYMBOL OF QUALITY
AN ISO 9001 COMPANY

JINDAL ALUMINIUM LTD.
BHIWADI-301019 (INDIA)

	NAME	DATE
DRAWN	ASHUTOSH	26-03-2024

CHECKED		
APPROVED		

SCALE	3:1
-------	-----

AREA mm ²	124.892
----------------------	---------

PERIMETER mm.	231.65
---------------	--------

WEIGHT kg/m	0.337
-------------	-------

DRAWING No.	SECTION No.
MAL NO-15154	
D6525	D6525

MAL NO-15154	
--------------	--

D6525	D6525
-------	-------

--	--

--	--

--	--

1. ALL DIMENSIONS ARE IN mm.
2. ROUND OFF ALL SHARP CORNERS WITH 0.30 mm.
3. TOLERANCES WILL BE AS PER BS:EN-755-9 , UNLESS OTHERWISE SPECIFIED

PARTY'S NAME	HARMONY SYSTEM
--------------	----------------

PARTY'S DRAWING No.	AS PER DRAWING-34TB34
---------------------	-----------------------

ALLOY & TEMPER	6063 T6	PRODUCT CODE:-051
		HSN CODE:- 76042990

DESCRIPTION	FURNITURE SECTION
-------------	-------------------