

ASSEMBLY

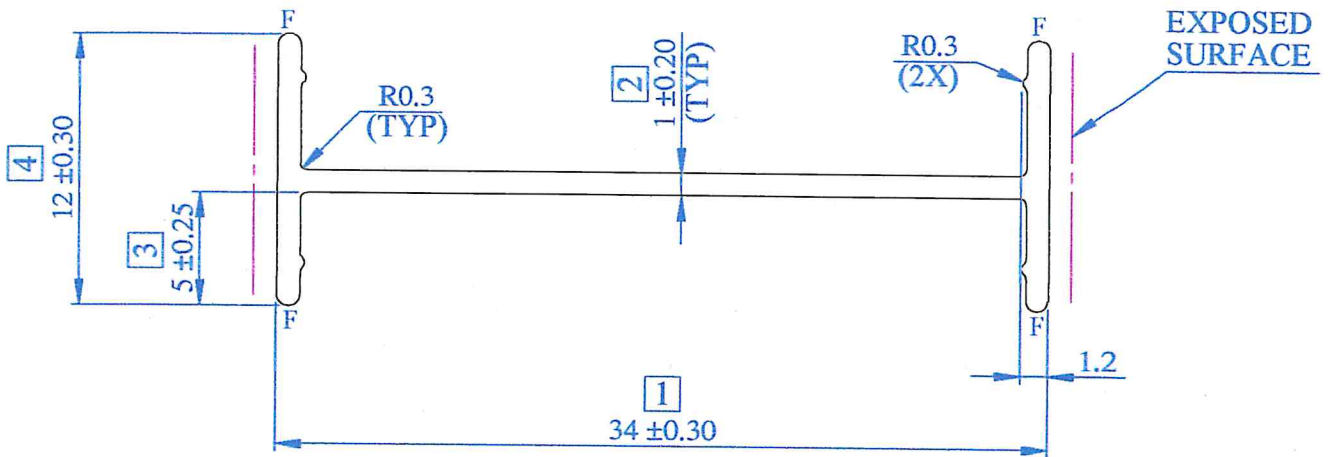
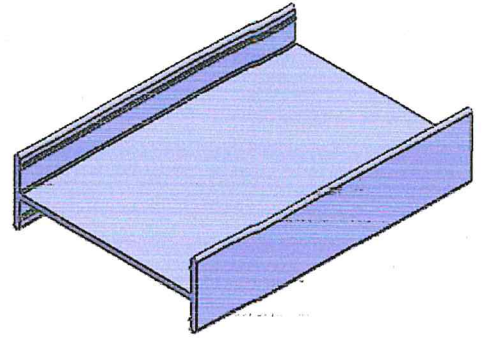

I - SECTION

NOTE:-

F= Full Radius

LOCATION:-P3 - 4HOLE
 ALL DIMENSION ARE IN mm.
 UNSPECIFIED CORNER RADIUS:0.40

PLEASE SPECIFY THE EXPOSED SURFACE

TOL. AS PER BS EN 755-9: 2008
 UNLESS SPECIFIED

TWIST= $\pm 1/4^\circ/300$ M.M./M.
 FLATNESS= WIDTH X 0.005mm.
 STRAIGHTNESS= 1.50 M.M./MTR.
 ANGULARITY= $\pm 1.5^\circ$

INDO ALUSYS INDUSTRIES LIMITED BHIWADI RAJASTHAN - 301019

PARTY SAMPLE & DRG. 34IS34		PARTY NAME M/S HARMONY SYSTEM			REF:- AS PER EMAIL ON Dt.-24.09.15		
			DRAWN	DHARMVIR	25.09.15	AREA	56.00 MM ²
			CHECKED	<i>[Signature]</i>		WEIGHT	0.151 KG/M.
			APPROVED	<i>[Signature]</i>	18/10/15	WT. RANGE	----- Kg/12'
			SCALE	1:1 & 3:1	DATE	ALLOY	6063-T6
00	(REF.)		CRITICAL DIM. *			MAL NO	15157
REV. STATUS	REV. NO.	DESCRIPTION	SIGN DATE	PERIMETER	INT.	SEC.NO.	D-6528
A4		REVISION			EXT.		