

MAL NO.-15212

D6536

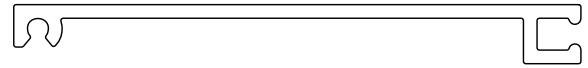

SCALE 1:1

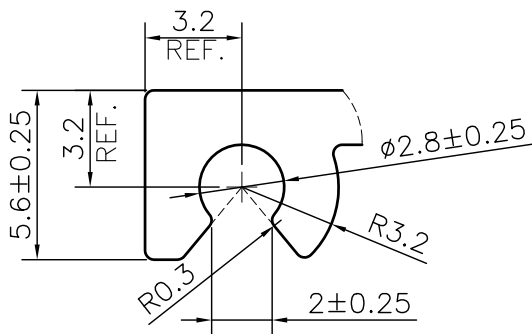
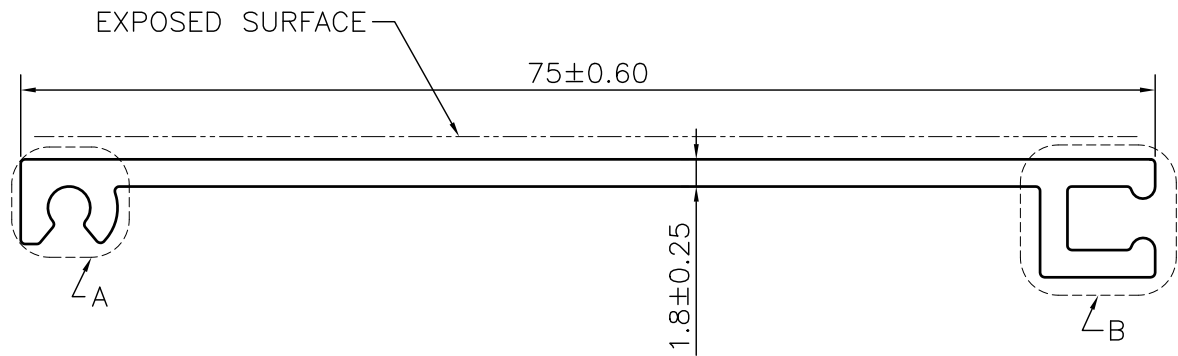

DETAIL A
SCALE 4:1

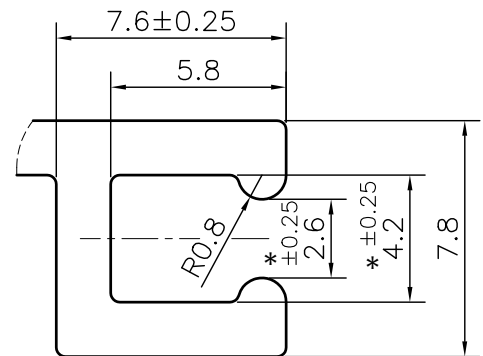

DETAIL B
SCALE 4:1

NOTE:-***= CRITICAL DIM. (2 PLACES)**

ROUND OFF ALL SHARP CORNERS WITH 0.30 mm.

1. STRAIGHTNESS= 1.7mm/M
2. TWIST= 1.7mm/M
3. ANGULARITY= $\pm 2^\circ$
4. FLATNESS= 0.007xWIDTH



SYMBOL OF QUALITY
AN ISO 9001 COMPANY

JINDAL ALUMINIUM LTD.
BHIWADI-301019 (INDIA)

	NAME	DATE
DRAWN	ASHUTOSH	29-11-2023
CHECKED		
APPROVED		
SCALE		2:1
AREA mm ²		172.02
PERIMETER mm.		190.7
WEIGHT kg/m		0.464
DRAWING No.	SECTION No.	
MAL NO.-15212	-	
D6536	D6536	

1. ALL DIMENSIONS ARE IN mm.
2. ROUND OFF ALL SHARP CORNERS WITH 0.40 mm.
3. TOLERANCES WILL BE AS PER BS:EN-755-9, UNLESS OTHERWISE SPECIFIED

PARTY'S NAME	HARMONY SYSTEM	
PARTY'S DRAWING No.	AS PER DRAWING	
ALLOY & TEMPER	6063 T6	PRODUCT CODE:-051
		HSN CODE:- 76042990
DESCRIPTION	FURNITURE SECTION	