

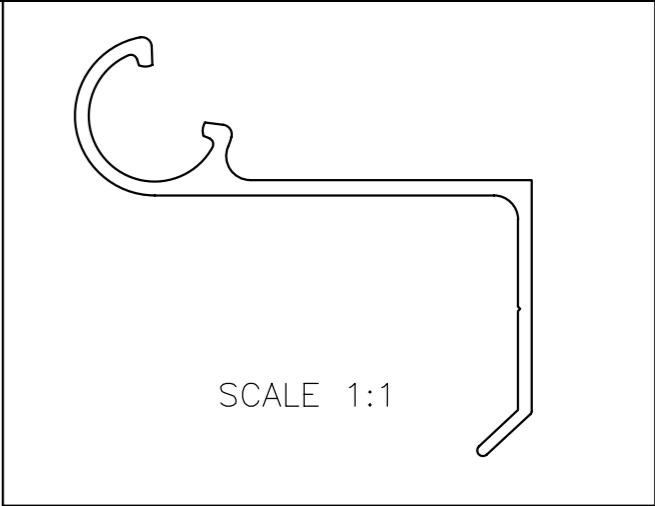

MAL-15990

D6950

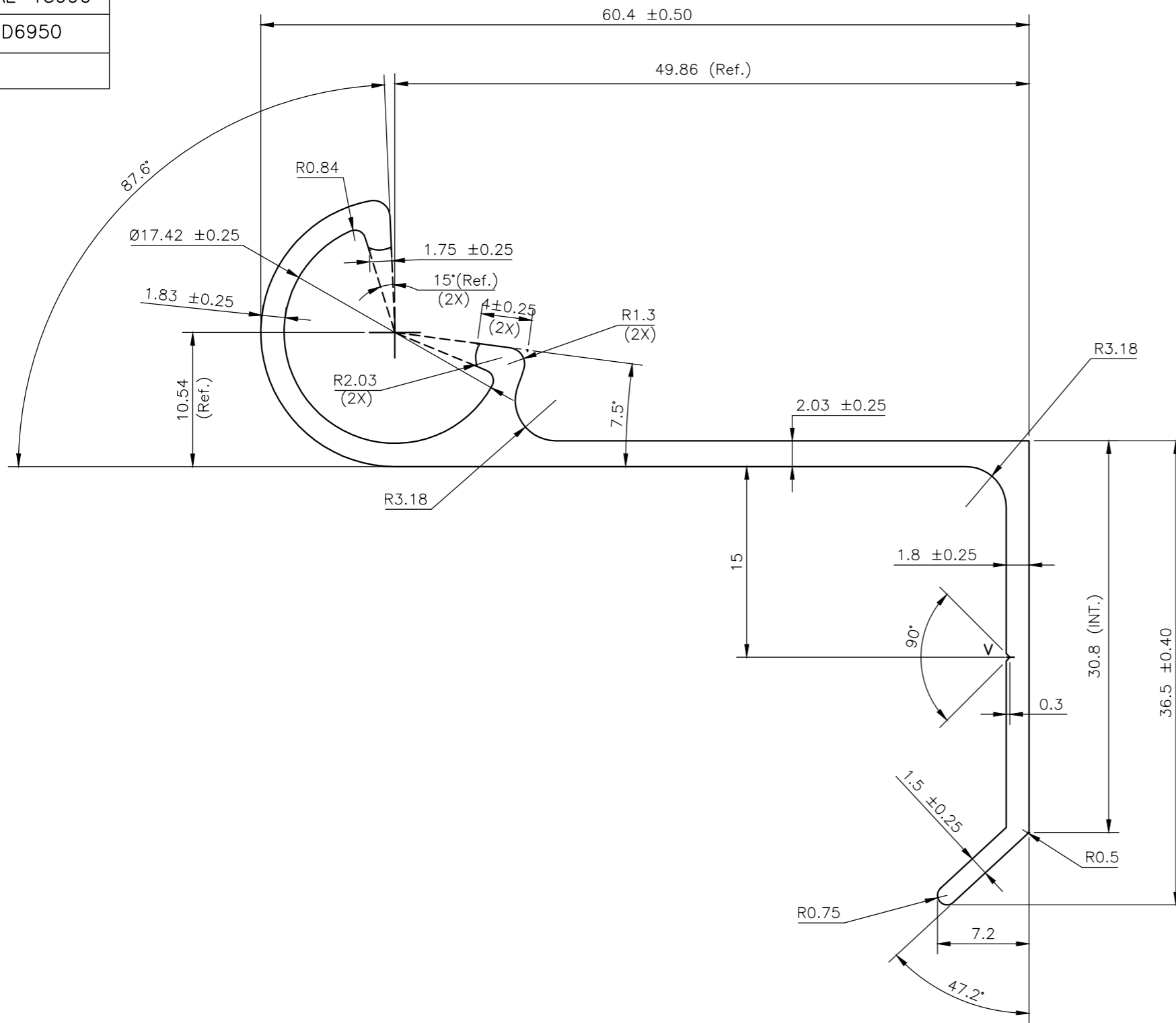

**NOTE:-**  
**V= 0.3x90° V-GROOVE**

TWIST= ±1/4°/300M.M./M.  
 FLATNESS=WIDTHX0.005mm.  
 STRAIGHTNESS= 1.5 M.M./MTR.  
 ANGULARITY= ±1.5°

 SYMBOL OF QUALITY AN ISO 9001 COMPANY	<b>JINDAL ALUMINIUM LTD.</b> BANGALORE-560073 (INDIA)	NAME	DATE
		DRAWN	ASHUTOSH 06-06-2022
1. ALL DIMENSIONS ARE IN mm. 2. ROUND OFF ALL SHARP CORNERS WITH 0.40 mm. 3. TOLERANCES WILL BE AS PER BS:EN-755-9 , UNLESS OTHERWISE SPECIFIED		CHECKED	
		APPROVED	
PARTY'S NAME M/S. INTEX HOME SOLUTIONS		SCALE	1:1&2.5:1
		AREA mm <sup>2</sup>	253.29
PARTY'S DRAWING No. AS PER DRAWING		PERIMETER mm.	250.32
		WEIGHT kg/m	0.684
ALLOY & TEMPER 6063-T6		DRAWING No.	SECTION No.
		MAL-15990	-
DESCRIPTION FURNITURE SECTION		D6950	D6950