

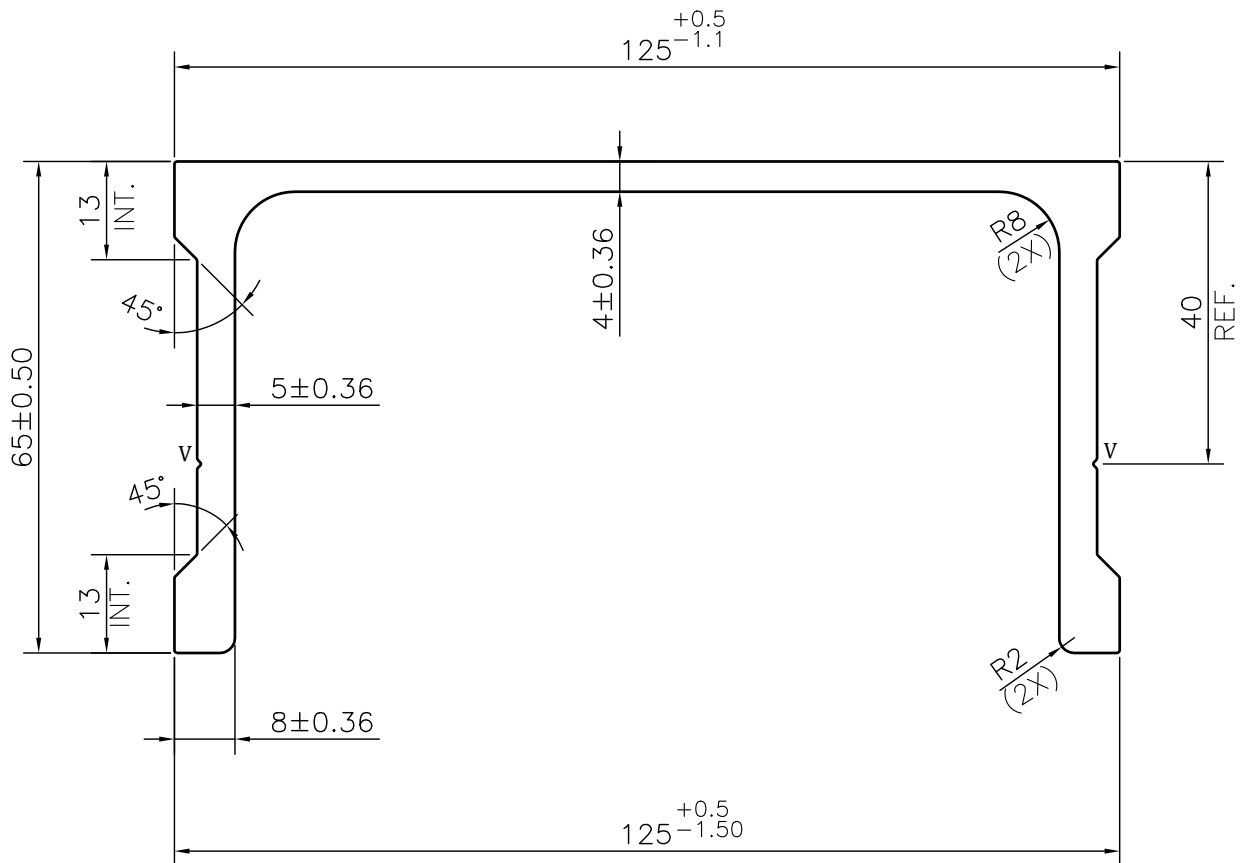

MAL NO-15912

D6963

**NOTE:-****V= 0.5x90° V-GOOVE (2 PLACES)**

 SYMBOL OF QUALITY AN ISO 9001 COMPANY	<b>JINDAL ALUMINIUM LTD.</b> <i>BHIWADI-301019 (INDIA)</i>	NAME	DATE
		DRAWN	ASHUTOSH 16-09-2023
		CHECKED	
		APPROVED	
1. ALL DIMENSIONS ARE IN mm. 2. ROUND OFF ALL SHARP CORNERS WITH 0.40 mm. 3. TOLERANCES WILL BE AS PER IS:3965-1981 , UNLESS OTHERWISE SPECIFIED		SCALE	1:1
		AREA mm <sup>2</sup>	1248.86
		PERIMETER mm.	498.27
PARTY'S NAME	MAINI SCAFFOLDING	WEIGHT kg/m	3.372
PARTY'S DRAWING No.	AS PER DRAWING	DRAWING No.	SECTION No.
ALLOY & TEMPER	6061 T6	MAL NO-15912	-
	PRODUCT CODE:-029	D6963	D6963
	HSN CODE:- 76042990		
DESCRIPTION	STRUCTURAL MISC. SECTION		