

IAL-16558

D7039

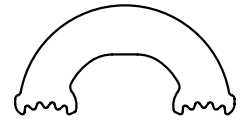

SCALE 1:1

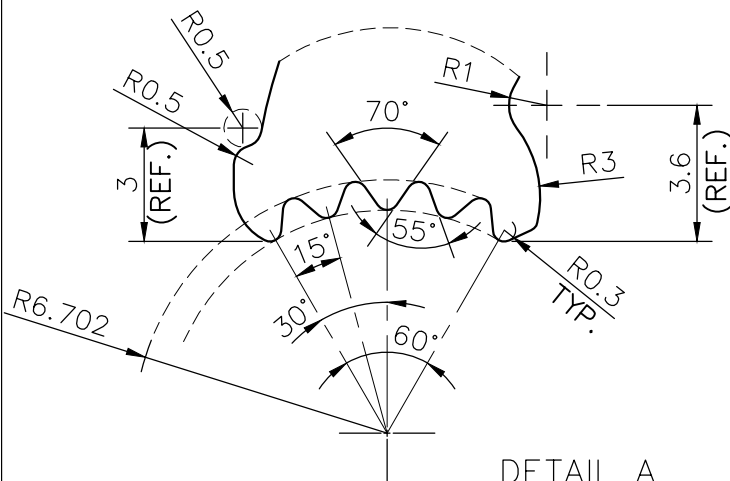
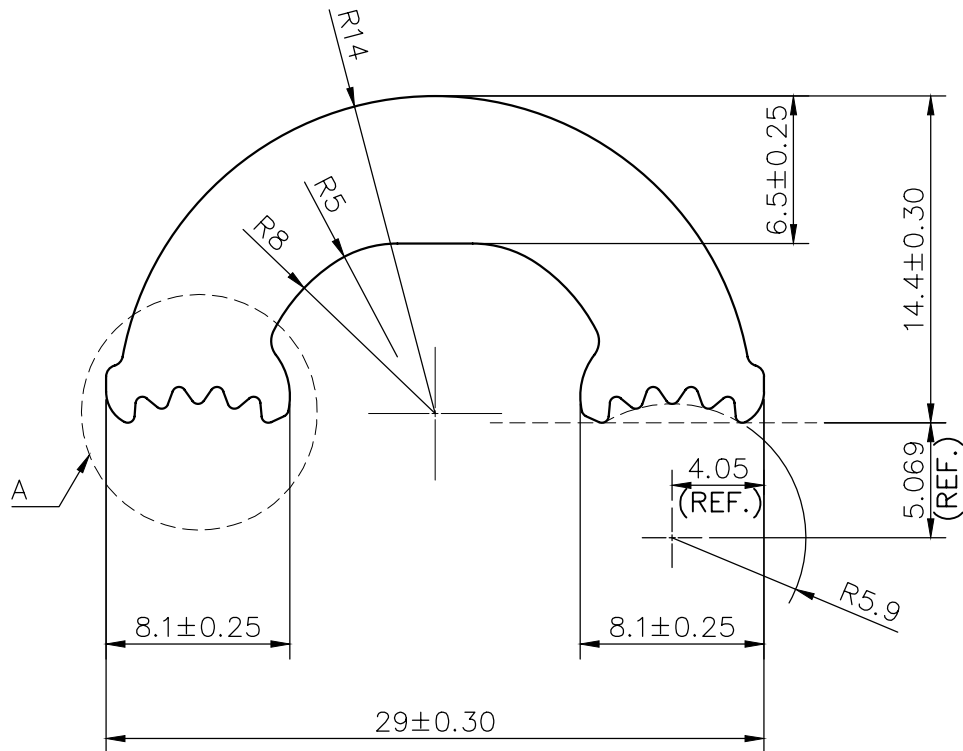

DETAIL A
SCALE 5:1

1. STRAIGHTNESS= 1.7mm/M
2. TWIST= 1.7mm/M
3. ANGULARITY= $\pm 2^\circ$
4. FLATNESS= 0.007xWIDTH



SYMBOL OF QUALITY
AN ISO 9001 COMPANY

JINDAL ALUMINIUM LTD.
BHIWADI-301019 (INDIA)

	NAME	DATE
DRAWN	ASHUTOSH	01-07-2023
CHECKED		
APPROVED		
SCALE	3:1	
AREA mm ²	212.50	
PERIMETER mm.	93.29	
WEIGHT kg/m	0.574	
DRAWING No.	SECTION No.	
IAL-16558		
D7039	D7039	

1. ALL DIMENSIONS ARE IN mm.
2. ROUND OFF ALL SHARP CORNERS WITH 0.40 mm.
3. TOLERANCES WILL BE AS PER BS:EN-755-9, UNLESS OTHERWISE SPECIFIED

PARTY'S NAME ENSTO INDIA PVT. LTD.

PARTY'S DRAWING No. AS PER DRAWING

ALLOY & TEMPER 6082-T6

DESCRIPTION ELECTRICAL SECTION