

MAL - 16768

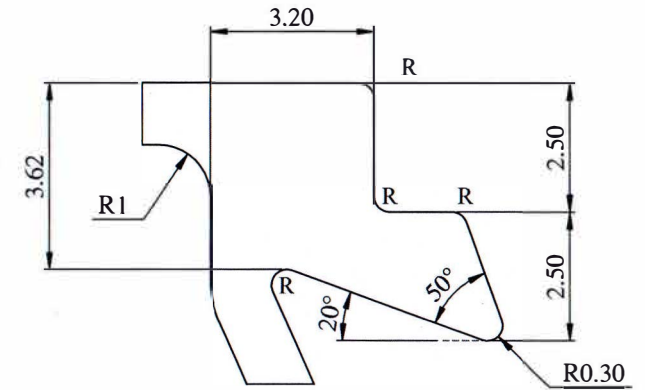

DETAIL "A"
 SCALE 10 : 1

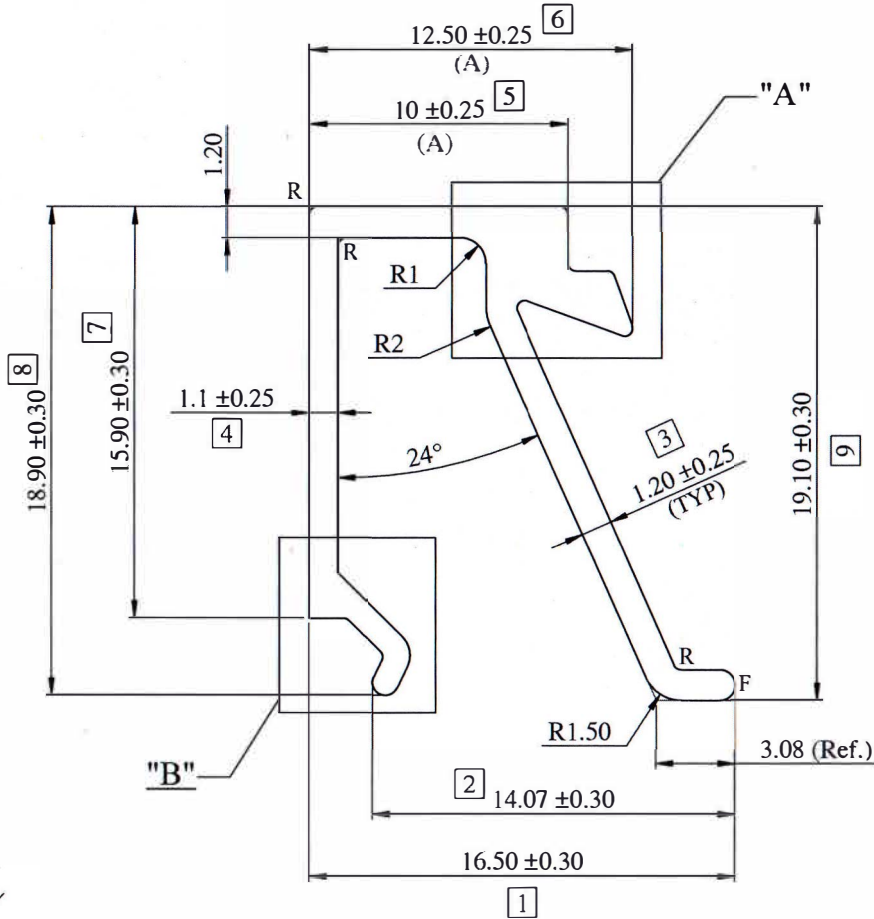
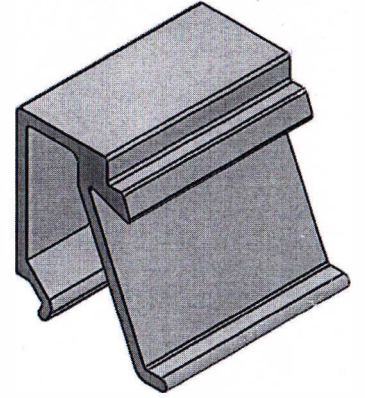
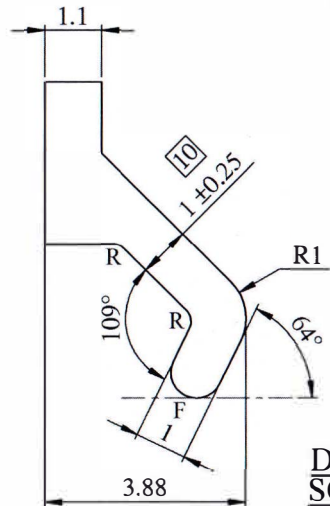

DETAIL "B"
 SCALE 10 : 1

NOTE:-

R = 0.30R
 F = Full Radius

LOCATION:- P2-HOLE
 ALL DIMENSION ARE IN mm.
 UNSPECIFIED CORNER RADIUS:0.40

PLEASE SPECIFY THE EXPOSED SURFACE

TOL. AS PER BS EN 755-9:2008
 UNLESS SPECIFIED

TWIST = ± 1°/300 M.M.
 FLATNESS = WIDTH X 0.005mm.
 STRAIGHTNESS = 1.50 M.M. MTR.
 ANGULARITY = ± 1.5°

| JINDAL ALUMINIUM LIMITED BHIWADI - 301019 | | | | | | | | | |
|---|----------|----------------------------------|---------------|-----------|-------------------------|-------------|---------------------------------|-----------|-----------------------|
| PARTY SAMPLE & DRG. | | SAMPLE | PARTY NAME | | M/S WORKSPACE SOLUTIONS | | REF:- AS PER EMAIL Dt.-04.12.17 | | |
| | | | | | DRAWN | VIVEK YADAV | 13.12.17 | AREA | 68.61 MM ² |
| | | | | | CHECKED | | | WEIGHT | 0.185 KG/M. |
| | | | | | APPROVED | | | WT. RANGE | ----- kg/12 |
| 001 | (A) | Dim. 10 was 11 & 12.50 was 13.50 | SCALE | 5:1 | DATE | 02.1.18 | ALLOY | 6063-T6 | |
| | (REF.) | As per email dt.- 19.12.17 | CRITICAL DIM. | * | | | MAL. NO | 16769 | |
| REV. STATUS | REV. NO. | DESCRIPTION | SIGN. DATE | PERIMETER | INT. .EXT. | | SEC.NO. | D-7071 | |
| A3 | | REVISION | | | | 107.20 | | | |