

IAL-D-7184

D7184

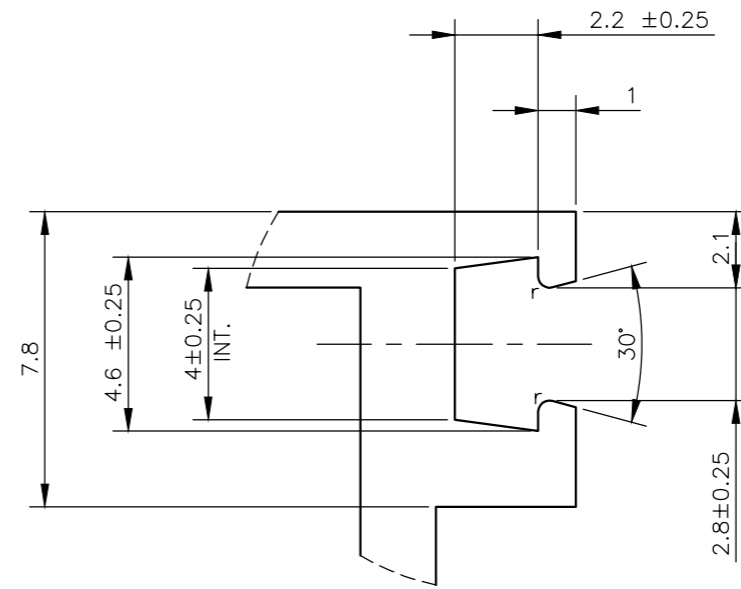

DETAIL B
SCALE 5:1

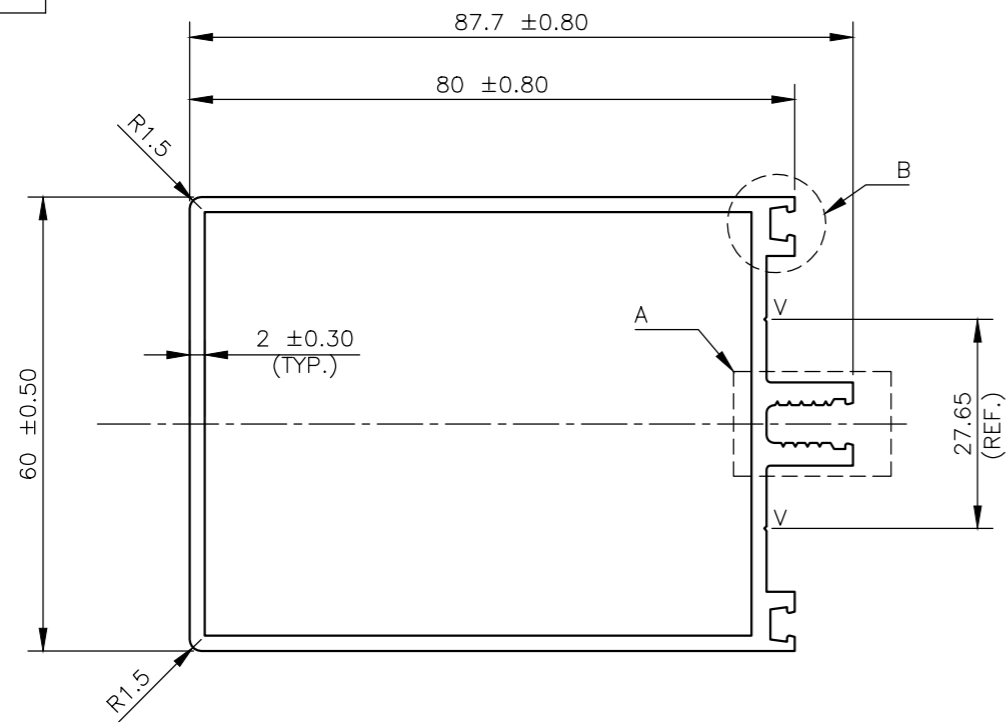
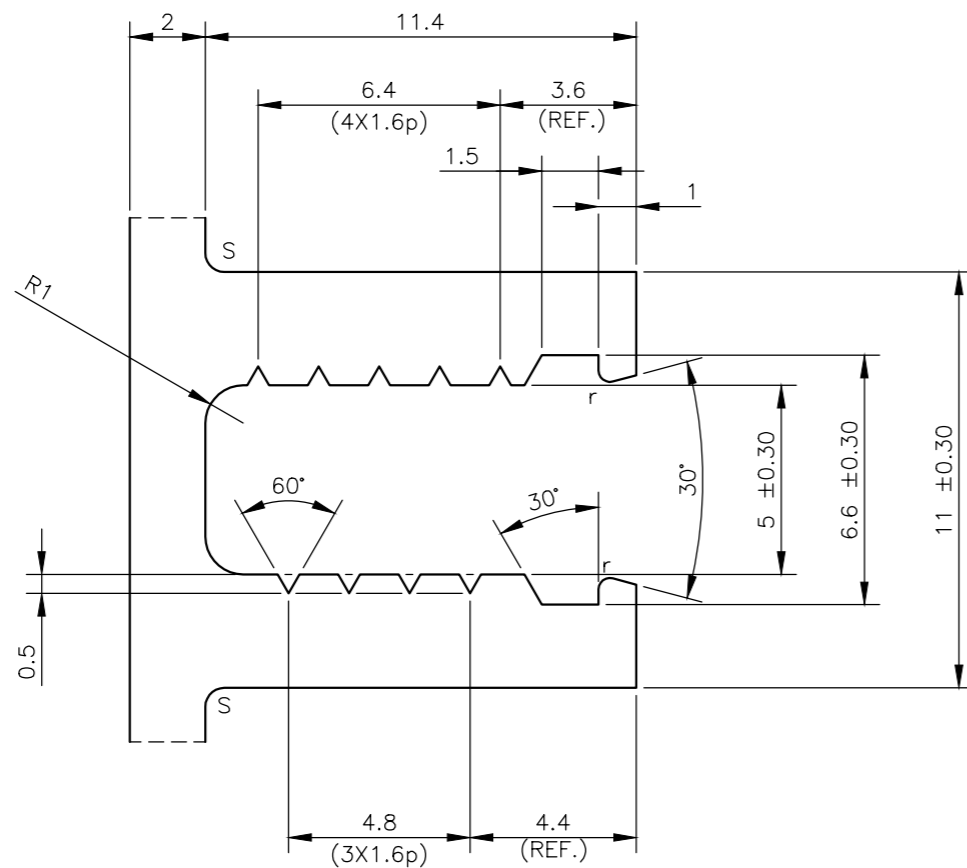

DETAIL A
SCALE 5:1

NOTE:-

$r=0.30R$
 $S=0.50R$
 $V=0.3X0.6X90^\circ$

TWIST= $\pm 1/4^\circ/300M.M./M.$
FLATNESS= $WIDTHX0.005mm.$
STRAIGHTNESS= $1.5 M.M./MTR.$
ANGULARITY= $\pm 1.5^\circ$

 SYMBOL OF QUALITY AN ISO 9001 COMPANY	JINDAL ALUMINIUM LTD. BANGALORE-560073 (INDIA)	NAME	DATE
		DRAWN	ASHUTOSH 12-05-2022
		CHECKED	
		APPROVED	
		SCALE	1:1
		AREA mm ²	625.65
		PERIMETER mm.	355.83
		WEIGHT kg/m	1.689
PARTY'S NAME	M/S. DAH	DRAWING No.	SECTION No.
PARTY'S DRAWING No.	AS PER DRAWING	IAL-D-7184	-
ALLOY & TEMPER	6063 T6	D7184	D7184
DESCRIPTION	CURTAIN WALL SECTION		