

MAL NO.-17064

D7247

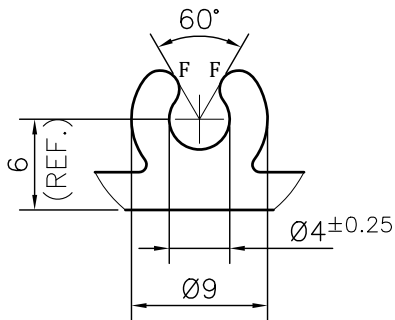
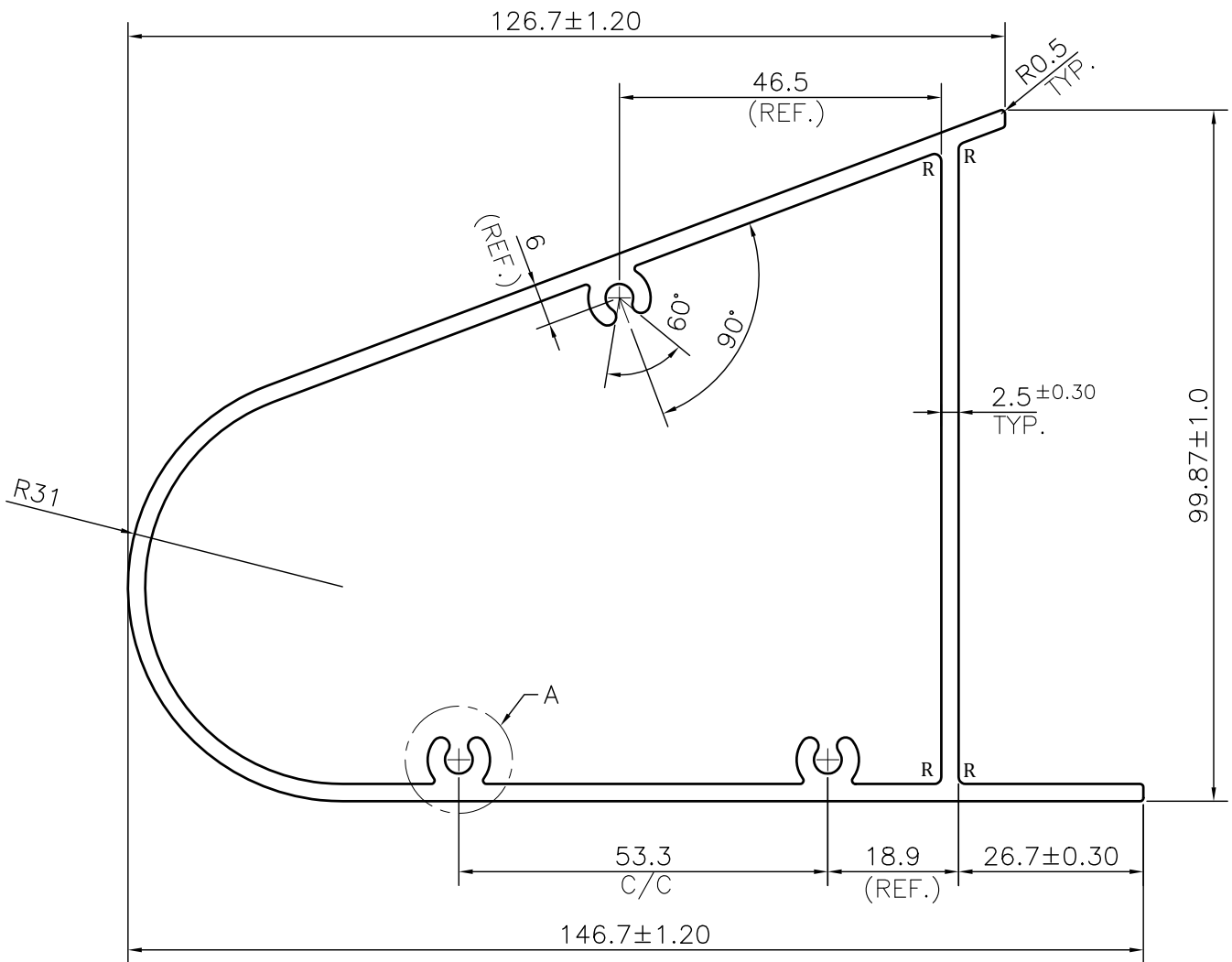

DETAIL A  
SCALE 2:1

**NOTE:-**

- R= 1.0 RADIUS (4 PLACES)**
- F= FULL RADIUS (6 PLACES)**

☞ ROUND OFF ALL SHARP CORNERS WITH 0.50 mm.

1. STRAIGHTNESS= 1.7mm/M
2. TWIST= 1.7mm/M
3. ANGULARITY= ±2°
4. FLATNESS= 0.007xWIDTH



SYMBOL OF QUALITY  
AN ISO 9001 COMPANY

**JINDAL ALUMINIUM LTD.**  
BHIWADI-301019 (INDIA)

	NAME	DATE
DRAWN	ASHUTOSH	18-04-2024
CHECKED		
APPROVED		
SCALE		1:1
AREA mm <sup>2</sup>		1123.409
PERIMETER mm.		445.668
WEIGHT kg/m		3.033
DRAWING No.	SECTION No.	
MAL NO.-17064	-	
D7247	D7247	

1. ALL DIMENSIONS ARE IN mm.
2. ROUND OFF ALL SHARP CORNERS WITH 0.50 mm.
3. TOLERANCES WILL BE AS PER BS:EN-755-9 , UNLESS OTHERWISE SPECIFIED

PARTY'S NAME	GREEN FACADE	
PARTY'S DRAWING No.	AS PER DRAWING	
ALLOY & TEMPER	6063 T6	PRODUCT CODE:-056
		HSN CODE:- 76042100
DESCRIPTION	ARCHITECTURAL MISC. SECTION	