

MAL NO-17420

D7319

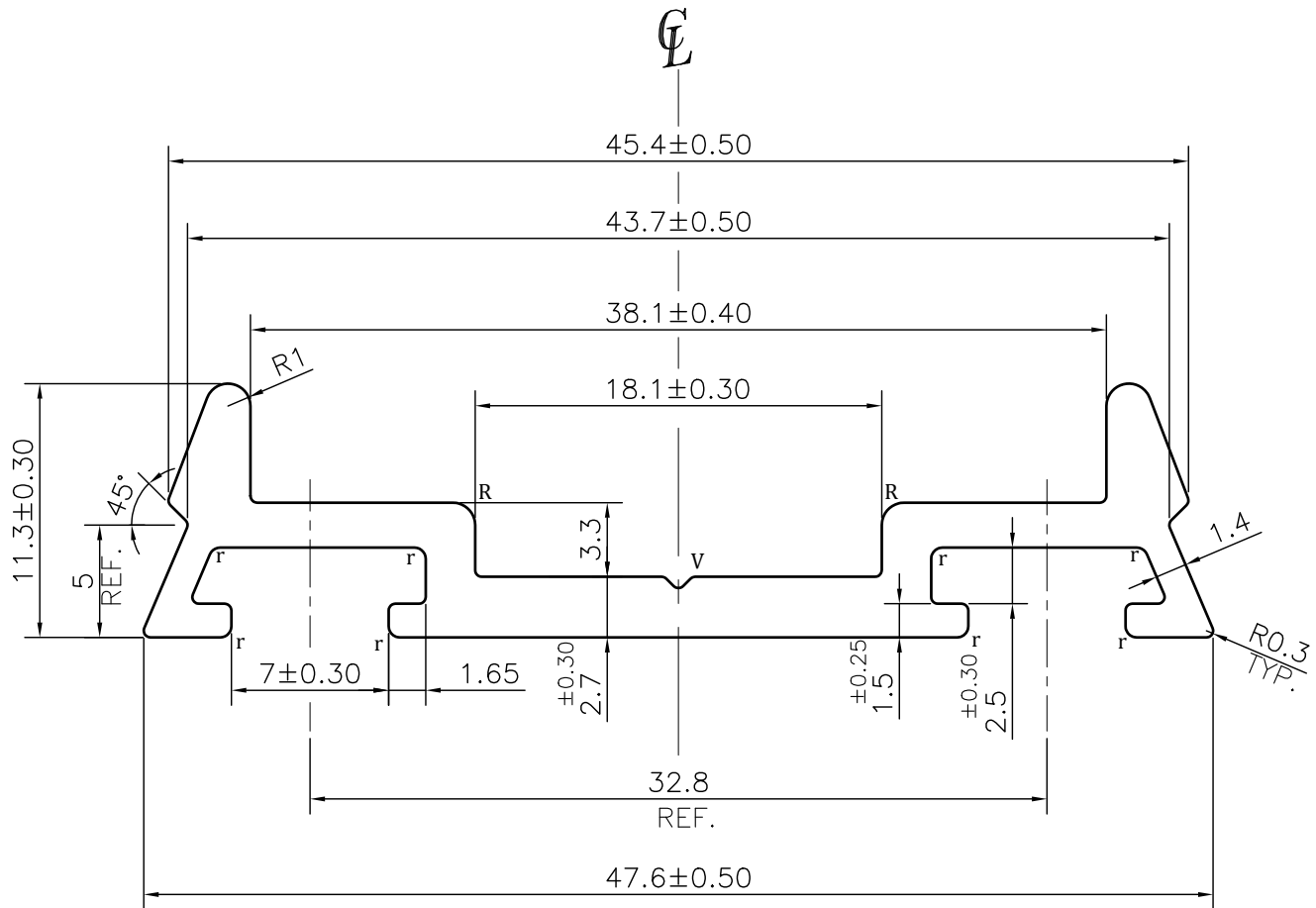

SCALE 1:1

**NOTE:-****r= 0.50 RADIUS (8 PLACES)****R= 1.0 RADIUS (2 PLACES)****V= 0.50x90° V-GROOVE (1 PLACE)**

ROUND OFF ALL SHARP CORNERS WITH 0.30 mm.

1. STRAIGHTNESS= 1.7mm/M
2. TWIST= 1.7mm/M
3. ANGULARITY= ±2°
4. FLATNESS= 0.007xWIDTH



SYMBOL OF QUALITY
AN ISO 9001 COMPANY

JINDAL ALUMINIUM LTD.
BHIWADI-301019 (INDIA)

	NAME	DATE
DRAWN	ASHUTOSH	06-10-2023

CHECKED

APPROVED

SCALE

3:1

AREA mm²

169.738

PERIMETER mm.

154.2

WEIGHT kg/m

0.458

DRAWING No.

SECTION No.

PARTY'S NAME

AXSYS SOLUTIONS

PARTY'S DRAWING No.

AS PER DRAWING

MAL NO-17420

-

ALLOY & TEMPER

6063 T6

PRODUCT CODE:-055

HSN CODE:- 76042990

D7319

D7319

DESCRIPTION

CURTAIN WALL SECTION